

## Instructions

# Tornado Plus™ Overhead Stirring System



Your Local Distributor



 **radleys**  
innovations for chemistry

Radleys  
Shire Hill, Saffron Walden, Essex, CB11 3AZ. United Kingdom.  
Tel: +44 1799 513320 Fax: +44 1799 513283  
Email: [sales@radleys.co.uk](mailto:sales@radleys.co.uk) Web: [www.radleys.com](http://www.radleys.com)

# Index

<b>Page 1</b>	<b>Index</b>
<b>Page 2</b>	<b>1. Introduction 2. Warranty 3. Servicing</b>
<b>Page 3</b>	<b>4. Safety Information 5. Important WARNINGS</b>
<b>Page 4</b>	<b>6. General Sizes &amp; Specifications</b>
<b>Page 5</b>	<b>7. Product Component Guide</b>
<b>Page 6</b>	<b>8. Products &amp; Accessories</b>
<b>Page 7</b>	<b>8. Products &amp; Accessories - Continued</b>
<b>Page 8</b>	<b>9. Glassware</b>
<b>Page 9</b>	<b>9. Glassware - Continued</b>
<b>Page 10</b>	<b>10. Quick Start Guide</b>
<b>Page 11</b>	<b>10. Quick Start Guide - Continued</b>
<b>Page 12</b>	<b>11. Set-Up &amp; Operation</b>
<b>Page 13</b>	<b>11. Set-Up &amp; Operation - Continued</b>
<b>Page 14</b>	<b>11. Set-Up &amp; Operation - Continued</b>
<b>Page 15</b>	<b>11. Set-Up &amp; Operation - Continued</b>
<b>Page 16</b>	<b>11. Set-Up &amp; Operation - Continued</b>
<b>Page 17</b>	<b>11. Set-Up &amp; Operation - Continued</b>
<b>Page 18</b>	<b>11. Set-Up &amp; Operation - Continued</b>
<b>Page 19</b>	<b>11. Set-Up &amp; Operation - Continued</b>
<b>Page 20</b>	<b>11. Set-Up &amp; Operation - Continued</b>
<b>Page 21</b>	<b>11. Set-Up &amp; Operation - Continued</b>
<b>Page 22</b>	<b>12. Maintenance &amp; Servicing</b>
<b>Page 23</b>	<b>12. Maintenance &amp; Servicing - Continued</b>
<b>Page 24</b>	<b>12. Maintenance &amp; Servicing - Continued</b>
<b>Page 25</b>	<b>WARRANTY - EMAIL BACK</b>

# 1. Introduction

---

**Thank you for purchasing your Tornado Plus Overhead Stirring System. Please read this Instruction Manual thoroughly before operating your unit.**

The Tornado integrates with the Carousel 6 Plus to offer powerful, overhead mechanical stirring, ideal for both viscous samples and for the dispersion of delicate solids in solution.

## Features

- Mechanical overhead stirring with a choice of three PTFE stirrer paddle styles; centrifugal, anchor and propeller.
- Uses a single overhead stirrer to stir all positions simultaneously - saving space and money compared with multiple set-ups. Compatible with all leading brands of overhead stirrer.
- Rapid and controlled heating to 180°C; with integral water cooled reflux head.
- Accepts 50ml, 100ml and 250ml round bottom flasks.
- Unique PEEK 'Pinch-Grip' mechanism allows easy, 'tool-free' stirrer shaft insertion and operation under an inert atmosphere.
- Exclusive wide neck flasks with quick coupling for improved sealing and ease of use.
- 2-speed drive allows overhead stirrers with less torque to be used for higher viscosities.
- Stir to 1000rpm in low viscosity solutions. Max. viscosity 10,000mPas at 500rpm.
- Integral polycarbonate safety guard prevents accidental contact with rotating parts.
- Stirrer Guide Assemblies now feature a 'quick-thread' for a gas tight seal to flasks.
- Exclusive wide neck flasks with quick coupling for improved sealing and ease of use.



# 2. Warranty

---

Tornado Plus Overhead Stirring System includes one year full parts and labour warranty from date of original purchase.

Warranty will only be valid if a completed Warranty Emal Back is returned within 1 month of date of purchase (see last page). In the event of product failure please contact your local distributor.

Please do not return any goods without prior agreement.

# 3. Servicing

---

The Tornado Plus contains moving parts that will wear and/or corrode over time, and this is particularly the case where aggressive solvents or solvent vapours are present. Therefore periodic servicing of your machine and the replacement of these parts is recommended. Please contact your local Radleys distributor for further information about your servicing options.

## 4. Safety Information

---

The following symbols are intended to assist the user in the safe and efficient operation of the Tornado Plus Overhead Stirring System.

	<p><b>Warning</b> Applies when there is a possibility of personal injury.</p>
<p>Important, Important, Important, Important, Important, Important, Important, Important, Important, Important, Important, Important,</p>	<p><b>Important Note</b> Alerts the user to important facts.</p>

## 5. Important WARNINGS

---

- Please read these instructions completely before using your Tornado Plus Overhead Stirring System.
- Please read the Carousel 6 Plus Reaction Station instructions in conjunction with these Tornado Plus Overhead Stirring System instructions before operating the system.
- Always fully read the instructions of any third party equipment, such as overhead stirrers thoroughly, to ensure you are not contravening any safety recommendations or manufacturers warranty when used in conjunction with the Tornado Plus Overhead Stirring System.
- Always ensure that the Tornado Plus assembly is clamped and supported correctly. Either by use of the recommended Universal Support Stand (RR99230) or by another separate support stand or framework. Under no circumstances should the system be operated without suitable support.
- It is the responsibility of the user to ensure the suitability of any supporting stand or framework.
- To avoid the build-up of limescale in the reflux head please avoid the use of hard water.
- Always ensure that the Tornado Plus is located onto a level surface.
- The Tornado Plus protective guard should always be in the down position during stirring to prevent risk of finger entrapment.
- The Tornado Plus components and Carousel's reaction flasks are not designed for pressurised reactions DO NOT PRESSURISE ABOVE 1psi.
- The Carousel is not suitable for continuous use under vacuum (e.g. for evaporations or for reactions to be carried out under vacuum). Vacuum should only be used intermittently as part of the inerting process.
- Maximum recommended operating temperature is 180°C.
- Operate only in a fumehood with protective safety sash.
- To avoid excessive corrosion over time always ensure that the six Stirrer Seal/Cap Assemblies are disassembled, cleaned and thoroughly dried after use. To minimise corrosion from aggressive vapours ideally these assemblies should also be stored outside of the fumehood when not in use.

Important, Important,  
Important, Important,  
Important, Important,  
Important, Important,  
Important, Important,  
Important, Important,

### Important Note

The Tornado Plus and Carousel 6 Plus should only be operated by trained and competent personnel. As with all chemistries, care should be taken to monitor your reactions at all stages. During operation the Tornado Plus and Carousel 6 Plus should not be left unattended unless in a supervised area.

## 6. General Sizes & Specifications

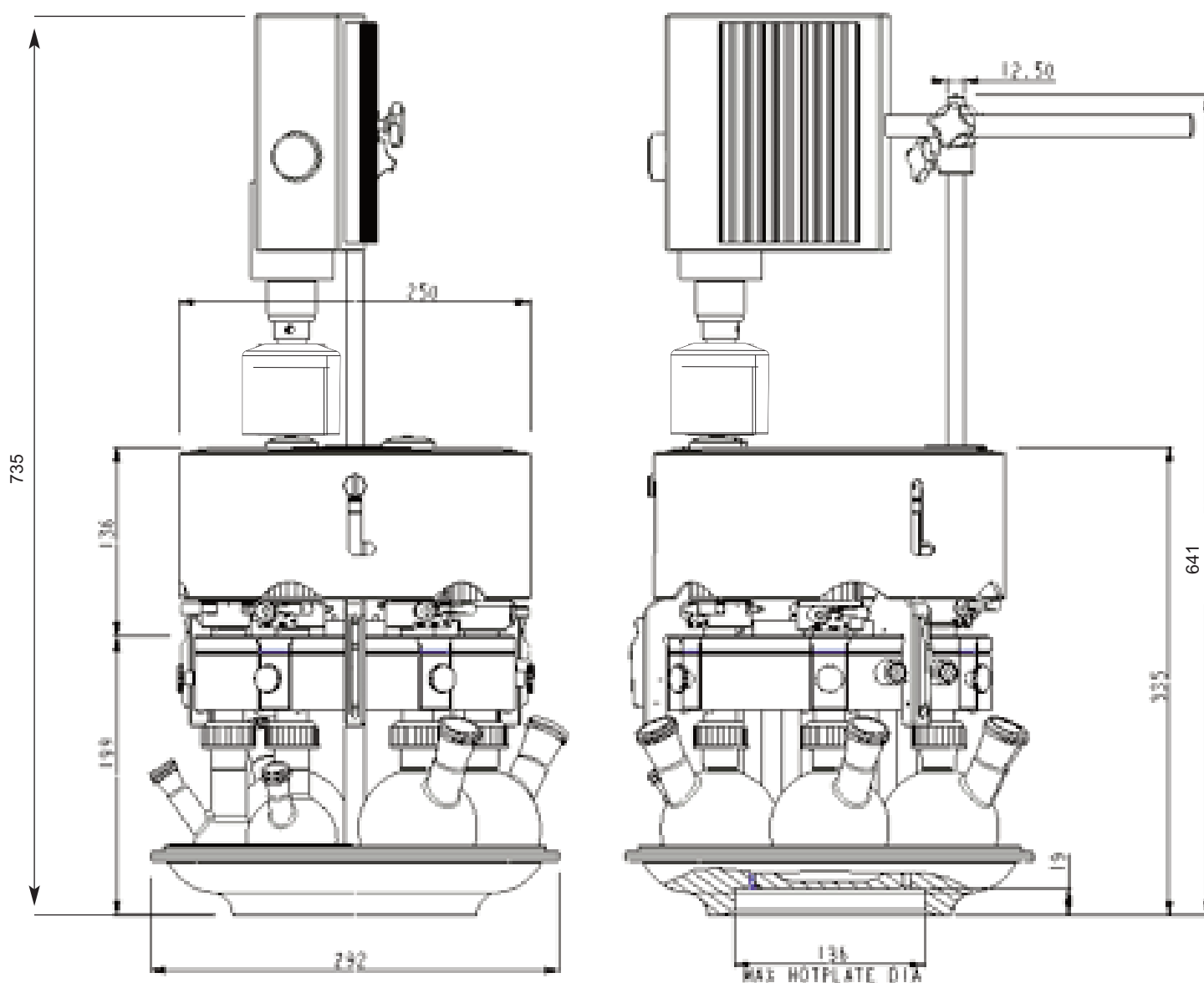

### General

Total Mass of Tornado Plus	Approximately 7Kg (does not include vessels, Carousel, hotplate, stand or overhead stirrer motor)
Drive ratios	1:1 for direct drive and 2:1 for higher torque applications
Stirrer speed	Max 1,000rpm
Motor fixing rod diameter	12mm
Drive Input connection	6mm Hexagonal shaft via flexible coupling
Stirring seal relief pressure	1 bar

### Motor requirements

Chuck Size	To accept 6mm shaft
Suggested motor Wattage	50W Min to 150W Max (depending on application)

### CE Conformity in accordance with EN 45014:1998

98/37/EC	Machinery Directive - and its amending directives
EN954-1:1996	Safety of Machinery - Safety-related Parts of Control Systems



## 7. Product Component Guide

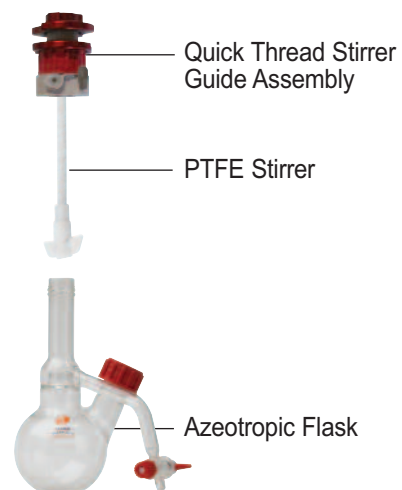
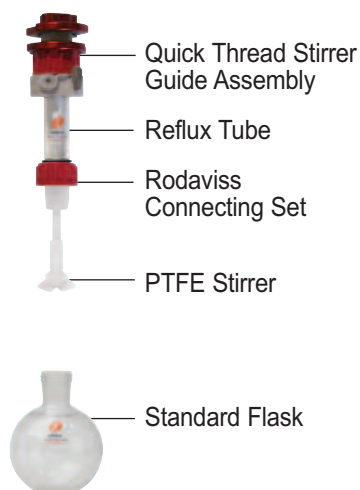
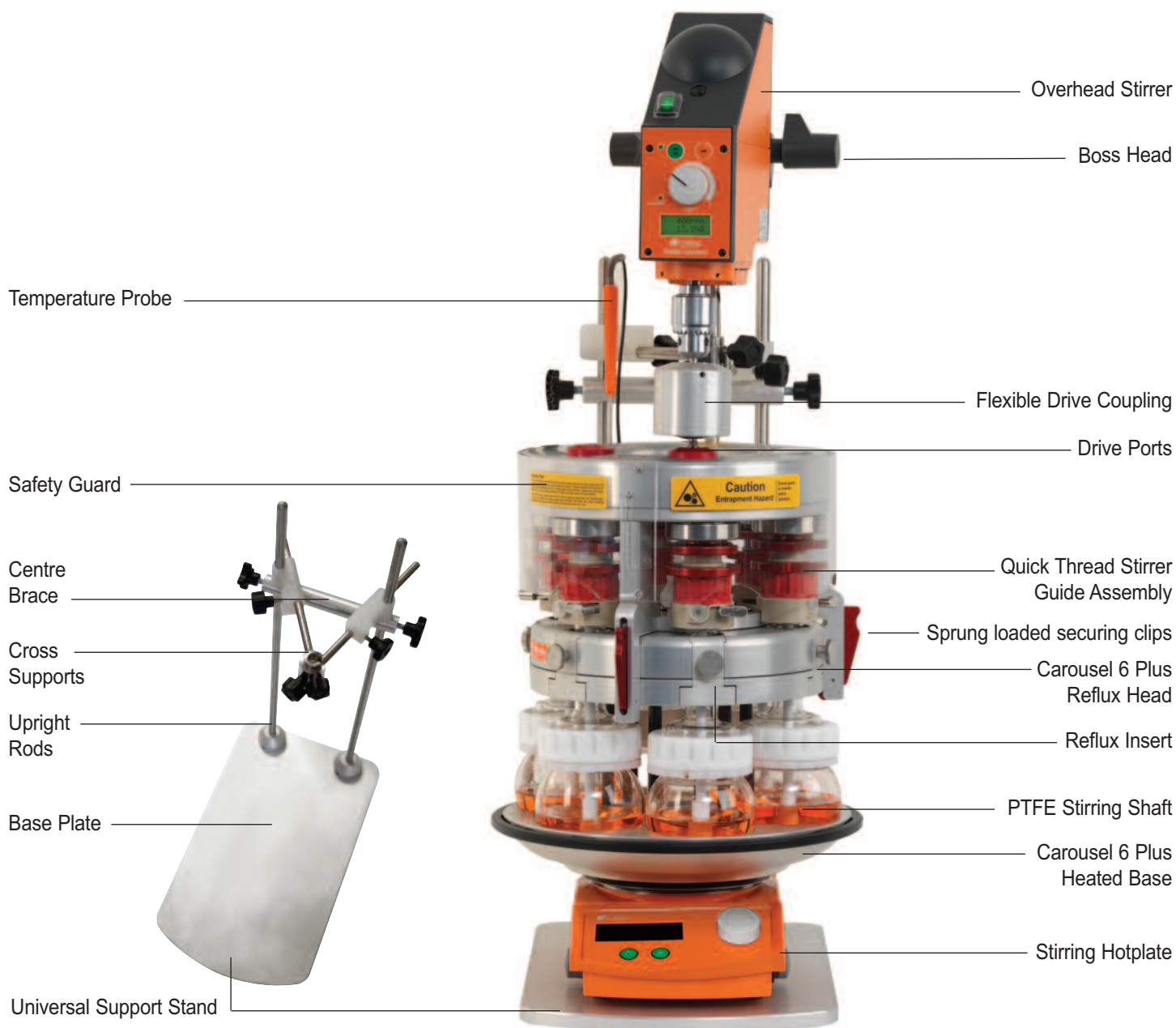

## 8. Products & Accessories

### Tornado Plus Overhead Stirring System

#### Tornado Plus

RR99951	Tornado Plus Overhead Stirring System
RR99230	Universal Support Stand
RR99237	Carousel Temperature Controller with extended 345mm Probe
RR71127	Temp Sensor Support Rod (13mm x 500mm)
RR71120	Support Rod Hotplate Adapter (extension plate)

Please contact Radleys for details of replacement parts for the Stirrer Guide and Tornado System.

### Carousel 6 Plus Reaction Station

#### Carousel 6 Plus

RR99916	Carousel 6 Plus Reaction Station
---------	----------------------------------

#### Carousel 6 Plus Systems

RR99942	Carousel 6 Plus System 33 - Heated System - Basic + Hotplate
RR99943	Carousel 6 Plus System 34 - Heated System - Basic
RR99944	Carousel 6 Plus System 35 - Heated System - Additions
RR99945	Carousel 6 Plus System 36 - Heated System - Comprehensive

### Overhead Stirrers

#### RS Overhead Stirrers

Please note that other overhead stirrer options are available on request, please contact Radleys for further information.

RR91302	RS27 Standard Overhead Stirrer 230v UK Plug
RR91302/EURO	RS27 Standard Overhead Stirrer 230v Euro Plug
RR91306	RS37 Digital Plus Overhead Stirrer 230v UK Plug
RR91306/EURO	RS37 Digital Plus Overhead Stirrer 230v Euro Plug
RR91308	RS50 Control Overhead Stirrer 230v UK Plug
RR91308/EURO	RS50 Control Overhead Stirrer 230v Euro Plug
RR91428	Remote Control for RS50 Control
RR91430	RS232 Interface Cable Stirrer-PC

Please contact Radleys for details of replacement parts for the Stirrer Guide and Tornado System.

### Stirring Hotplates

#### Tech Stirring Hotplates

RR91202	Carousel Tech Stirring Hotplate 230v UK Plug
RR91202/EURO	Carousel Tech Stirring Hotplate 230v Euro Plug
RR91202/JAP	Carousel Tech Stirring Hotplate 110v Japanese Plug
RR91202/SWISS	Carousel Tech Stirring Hotplate 240v Swiss Plug
RR91202/USA	Carousel Tech Stirring Hotplate 115v US Plug

#### Advanced Stirring Hotplates

RR91204	Carousel Advanced Stirring Hotplate 230v UK Plug
RR91204/EURO	Carousel Advanced Stirring Hotplate 230v Euro Plug
RR91204/JAP	Carousel Advanced Stirring Hotplate 100V Japanese Plug
RR91204/SWISS	Carousel Advanced Stirring Hotplate 230v Swiss Plug
RR91204/USA	Carousel Advanced Stirring Hotplate 115V US Plug

Other Stirring Hotplate models are available on request...

#### Pt1000 Temperature Sensors and Accessories

RR91226	Pt1000 S/S Temperature Sensor
RR99239	Pt1000 S/S Temperature Sensor with 345mm Probe Allows probe to reach through Tornado unit into Carousel 6 base
RR91227	Pt1000 Glass Coated Temperature Sensor
RR91228	Temperature Sensor Holder
RR91235	Pt1000 Clamping System - support rod and cable guide
RR91236	Pt1000 Clamping System - support rod and cable guide (for bath from 3 to 5 litres)
RR91229	Support Rod (13mm x 425mm)
RR71127	Support Rod (13mm x 500mm)
RR71125	Support Rod (13mm x 340mm)
RR71120	Support Rod Hotplate Adapter (extension plate)
RR91234	RS232 Interface Cable - 15 Pin to 9 Pin

### Tornado Plus Accessories

#### Spare Parts

RR99952	Quick-Thread Stirrer Guide Assembly
RR99953	Replacement Tubing for RR99952 110mm (Stirrer Guide to gas manifold)

#### PTFE Stirring Paddles

RR99240	Centrifugal PTFE Stirrer Paddle, pk 6
RR99241	Centrifugal PTFE Stirrer Paddle, pk 1
RR99244	Anchor PTFE Stirrer Paddle for 100ml Flasks, pk 6
RR99245	Anchor PTFE Stirrer Paddle for 100ml Flasks, pk 1
RR99248	Anchor PTFE Stirrer Paddle for 250ml Flasks, pk 6
RR99249	Anchor PTFE Stirrer Paddle for 250ml Flasks, pk 1
RR99251	Propellor PTFE Stirrer Paddle, pk 6
RR99252	Propellor PTFE Stirrer Paddle, pk 1

#### Aluminium Inserts

RR99140	Aluminium Insert for 25ml Reaction Flask, pk 6
RR99060	Aluminium Insert for 50ml Reaction Flask, pk 6
RR99058	Aluminium Insert for 100ml Reaction Flask, pk 6
RR99057	Aluminium Insert for 170ml Reaction Flask, pk 6

#### Replacement O-Rings & Quick Release Couplings

RR91060	Nitrile O-Rings 4mm Gas Outlet - Bottom, pk 50
RR91061	Nitrile O-Rings 3mm Gas Outlet - Top, pk 50
RR91062	Viton O-Rings 4mm Gas Outlet - Bottom, pk 50
RR91063	Viton O-Rings 3mm Gas Outlet - Top, pk 50
RR91065	Quick Release Male Body Coupling No Shut-off, pk 2
RR91066	Quick Release Barbed Coupling No Shut-off
RR99062	Quick Release Barbed Coupling + Shut-off, pk 2
RR99063	90° Elbow Quick Release Barbed Coupling + Shut-off, pk 2
RR99065	Quick Release Male Body Coupling + Shut-off, pk 2

#### Rodaviss Caps & Connecting Sets

RR99051	B14/23 Rodaviss Sealing Cap, pk 10
RR99043	B24/29 Rodaviss Sealing Cap, pk 10
RR99955	B14/23 Rodaviss Connecting Set, pk 10
RR99044	B24/29 Rodaviss Connecting Set, pk 10
RR99080	PTFE/Silicone Septa 20mm - B14/23, pk 50
RR99081	PTFE/Silicone Septa 24.5mm - B19/26, pk 50
RR99082	PTFE/Silicone Septa 29mm - B24/29, pk 50
RR99068	B14/23 Rodaviss Connecting Cap, pk 10
RR99090	B24/29 Rodaviss Connecting Cap, pk 10

#### Other Accessories

RR98906	Black Lab Marker, pk 10
RR99061	Reaction Flask Support Ring, pk 6
RR99067	Tubing for Inert Gas or Reflux Cooling 2 metres

## 8. Products & Accessories

### Glassware

#### Standard Flasks & Reflux Tubes

RR99070	50ml Reaction Flask, pk 6
RR99054	100ml Reaction Flask, pk 6
RR99052	170ml Reaction Flask, pk 6
RR99041	250ml Reaction Flask, pk 6
RR99917	250ml Reaction Flask + Reflux Tube + Connecting Set, pk 6
RR99918	B24/29 Reflux Tube + Connecting Set, pk 6
RR99919	250ml Long Neck Reaction Flask, pk 6

#### Standard Flasks with Sidearms

RR99071	50ml Reaction Flask with B14/23 Sidearm + Septa Port, pk 6
RR99074	100ml Reaction Flask with B14/23 Sidearm + Septa Port, pk 6
RR99077	250ml Reaction Flask with B24/29 Sidearm + Septa Port, pk 6
RR99047	250ml Reaction Flask with B14/23 Sidearm + Septa Port, pk 6
RR99087	250ml Reaction Flask with 2x B14/23 Sidearms + Septa Port, pk 6
RR99088	250ml Reaction Flask with 2x B24/29 Sidearms + Septa Port, pk 6
RR99089	250ml Reaction Flask with 1x B14/23 + 1x B24/29 Sidearm + Septa Port, pk 6

#### Wide Neck Flasks with Coupling

RR99924	Wide Neck Reflux Tube + Coupling
RR99925	Coupling for Wide Neck Flasks
RR99940	PTFE Wide Neck Support Collar
RR99941	Nitrile O-Ring for PTFE Wide Neck Support Collar
RR99956	FEP O-Ring for PTFE Wide Neck Support Collar
RR99926	50ml Wide Neck Flask
RR99928	100ml Wide Neck Flask
RR99933	250ml Wide Neck Flask

#### Wide Neck Flasks with Sidearms

RR99927	50ml Wide Neck Flask with B14/23 Sidearm + Septa Port
RR99929	100ml Wide Neck Flask with B14/23 Sidearm + Septa Port
RR99930	100ml Wide Neck Flask with 2x B14/23 Sidearms + Septa Port
RR99934	250ml Wide Neck Flask with B24/29 Sidearm + Septa Port
RR99935	250ml Wide Neck Flask with 2x B24/29 Sidearms + Septa Port

#### Wide Neck Flasks with Baffles & Sidearms

RR99931	100ml Baffled Wide Neck Flask with B14/23 Sidearm + Septa Port
RR99932	100ml Baffled Wide Neck Flask with 2x B14/23 Sidearms + Septa Port
RR99936	250ml Baffled Wide Neck Flask with B24/29 Sidearm + Septa Port
RR99937	250ml Baffled Wide Neck Flask with 2x B24/29 Sidearms + Septa Port

#### Azeotropic Glassware

RR99922	100ml Azeotropic Reaction Flask, pk 3
RR99920	250ml Azeotropic Reaction Flask, pk 3
RR99939	100ml Tornado Azeotropic Reaction Flask, pk 3
RR99938	250ml Tornado Azeotropic Reaction Flask, pk 3

#### Liquid & Solid Addition Funnels

RR99049	B14/23 Solid Additions Funnel, pk 3
RR99079	B24/29 Solid Additions Funnel, pk 3
RR99048	B14/23 Liquid Additions Dropping Funnel + Pressure Equalising Arm, pk 3
RR99078	B24/29 Liquid Additions Dropping Funnel + Pressure Equalising Arm, pk 3

#### Evaporation Adapters, Splash Heads & Evaporation Flasks

RR99045	Rotary Evaporator Adapters Rodaviss B29 Socket to B24 Cone, pk 2
RR99046	Rotary Evaporator Adapters Ordinary B29 Socket to B24 Cone, pk 2
RR99055	Rotary Evaporator Adapters USA 24/40 Socket to B24 Cone, pk 2
RR99083	Splash Head Rodaviss B29 Socket to B24 Cone
RR99084	Splash Head Ordinary B29 Socket to B24 Cone
RR99085	Splash Head USA 24/40 Socket to B24 Cone
RR99053	250ml EZ-2/HT Evaporation Flask (Compatible with Genevac Evaporators), pk 4

Flasks are NOT supplied with reflux tubes or PTFE caps, these must be purchased separately.

### Storm & Breeze Heating/Cooling Work Stations

#### Storm & Breeze Work Stations

RR96200	Storm Work Station + Carousel 6 PTFE Insulating Plates (M24 hose connections)
RR96210	Breeze Work Station + Integral Stand (M16 hose connections)
RR96220	PTFE Insulating Plates for Carousel 6 Plus

#### Insulated Hoses

HB6084	Insulated Hose - 100cm long, with M16 thread
HB6085	Insulated Hose - 150cm long, with M16 thread
HB6136	Insulated Hose - 200cm long, with M16 thread
HB6255	Insulated Hose - 300cm long, with M16 thread
HB6784	Insulated Hose - 100cm long, with M24 thread
HB6785	Insulated Hose - 150cm long, with M24 thread
HB6786	Insulated Hose - 200cm long, with M24 thread
HB6787	Insulated Hose - 300cm long, with M24 thread

#### M16 Hose Adapters & Valves

HB6945	M16 Female to M24 Male Adapter
HB6431	M16 Female to M30 Male Adapter
HB6195	M16 90 Degree Adapter
HB6091	M16 Ball Valve
RR96316	M16 Thread Protection Cap, pk 10

#### M24 Hose Adapters & Valves

HB6724	M24 Female to M16 Male Adapter
HB6723	M24 Female to M30 Male Adapter
HB9256	M24 90 Degree Adapter
HB9236	M24 Ball Valve
RR96336	M24 Thread Protection Cap, pk 10

#### M30 Hose Adapters & Valves

HB6454	M30 Female to M16 Male Adapter
HB9268	M30 Female to M24 Male Adapter
HB6461	M30 90 Degree Adapter
HB6451	M30 Ball Valve
RR96348	M30 Thread Protection Cap, pk 10

#### Thermofluids

HB6164	Silicone Oil -40°C to +165°C - 10 litres
HB6162	Silicone Oil -20°C to +235°C - 10 litres
HB6479	DWTherm -90°C to +200°C - 10 litres



## 9. Glassware

### 9.1 Standard Flasks

- Constructed of heavy duty, borosilicate glass.
- Choice of sizes: 50ml, 100ml, 170ml and 250ml (5ml, 10ml, 25ml flasks are available but are not compatible with the Tornado Plus)
- Precision engineered round bottom design ensures an excellent fit with the Carousel's wells, maximising heat transfer.
- Flasks feature a B24/B29 Rodaviss joint for connection to the detachable Reflux Tube.
- Reflux Tubes feature a quick-thread, which when combined with PTFE Easy-On Cap, give a gas tight seal up to 1psi.
- Optional single piece 250ml Long Neck design.
- Compatible with magnetic stirring bars and the centrifugal stirrer paddles (Tornado).
- Flasks are NOT supplied with reflux tubes or PTFE caps, which must be ordered separately.

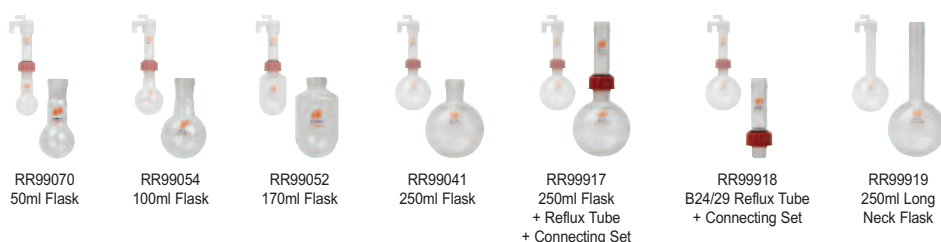

### 9.2 Standard Flasks with Sidearms

- Sidearm flasks have all the features of the standard flasks with the addition of either one or two sidearms.
- Flasks are available with B14/23 and B24/29 sidearm options and include Rodaviss caps and sealing septa.
- Sidearms are compatible with Dropping Funnels and Solid Addition Funnels.



### 9.3 Azeotropic Flasks (Dean and Stark)

- Unique single piece flasks fit directly into the Carousel 6 Plus, allowing chemists to perform up to six Azeotropic processes in parallel.
- Choice of sizes: 100ml and 250ml.
- Special Tornado version with wider neck is designed to accept centrifugal stirring paddle.
- Flasks feature a replaceable PTFE stopcock for removal of the aqueous phase.
- Feature B14/23 or B24/29 sidearms.
- Sidearms are compatible with Dropping Funnels and Solid Addition Funnels.

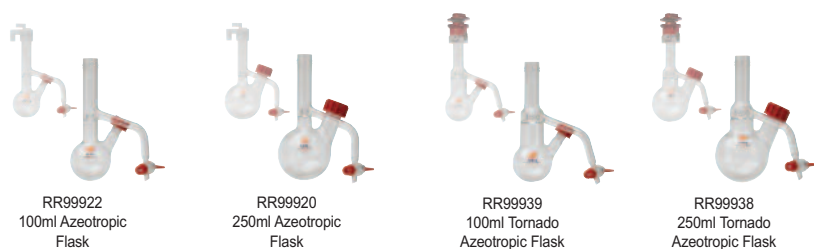

## 9. Glassware - Continued

### 9.4 Wide Neck flasks with quick coupling

- Wide neck flasks allow easier removal of viscous or solid samples and facilitate the use of the anchor and propeller style PTFE stirrer blade options (Tornado).
- These unique vessels feature a 50mm ID flat flange, which combines with a Nitrile O-ring and our unique self centering PTFE collar to offer a leak-tight seal between the glass flask and wide neck reflux tube.
- The two flanges are compressed together using a two part threaded polymer coupling, which both holds the components rigid and offers an excellent gas tight seal.

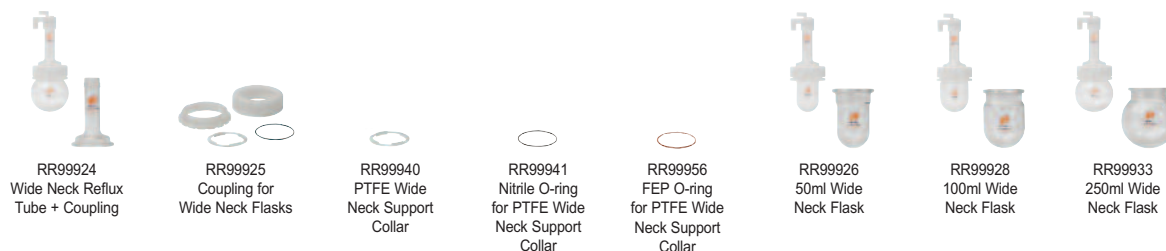

### 9.5 Wide Neck flasks with Sidearms

- Wide neck sidearm flasks have all the features of the wide neck flasks with either one or two sidearms. Ideal for attaching dropping funnels or powder funnels.



### 9.6 Wide Neck flasks with Baffles and Sidearms

- Wide necked baffled flasks improve the turbulence within the flask by disrupting the creation of a central vortex. Baffled flasks are recommended for use with stirrer paddles for maximum effect.

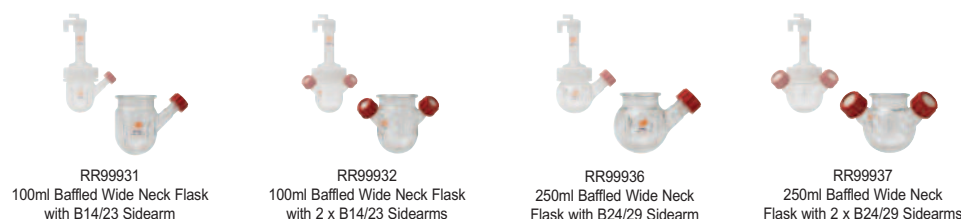

### 9.7 Sundry Glassware

- Choice of 50ml Liquid Additions Dropping Funnels with B14/23 or B24/29 Rodaviss joints.
- The dropping funnels are ideal for the controlled addition of larger volumes of reagent directly into the reaction flask. Funnels feature a drip cone and pressure equalising arm for ease of addition.
- Choice of Solid Additions Funnel with B14/23 or B24/29 Rodaviss joints; ideal for the addition of powders or solids into the reaction flask.



## 10. Quick Start Guide

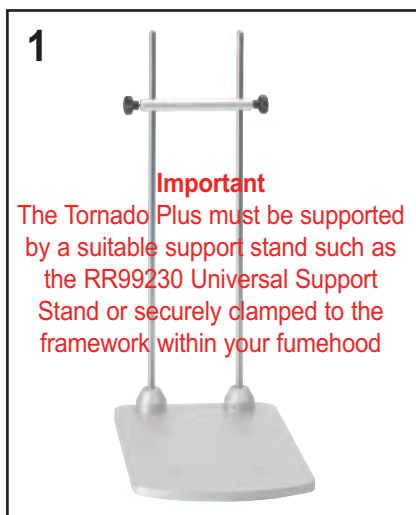

Assemble Universal Support Stand as per instructions. The Tornado Plus should not be moved after assembly.



Locate the stirring hotplate onto the Support Stand.



Locate Carousel 6 Plus on to stirring hotplate.



Screw support rod into threaded hole in top of Tornado Plus using the spanner provided.

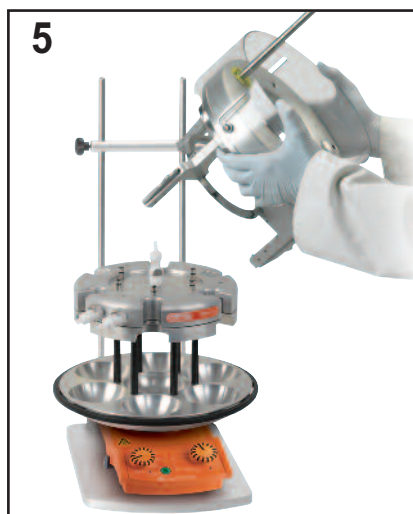

Locate Tornado onto the Carousel aligning the temperature probe holes.

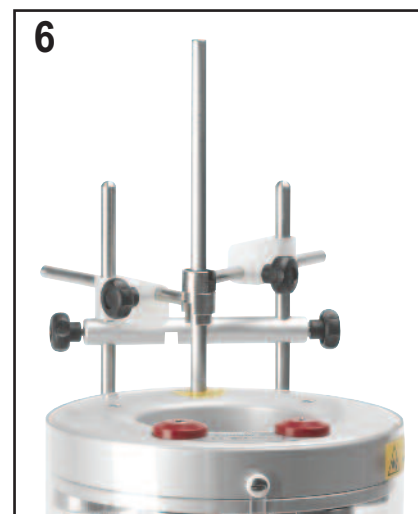

Secure cross supports firmly around Tornado Plus support rod.

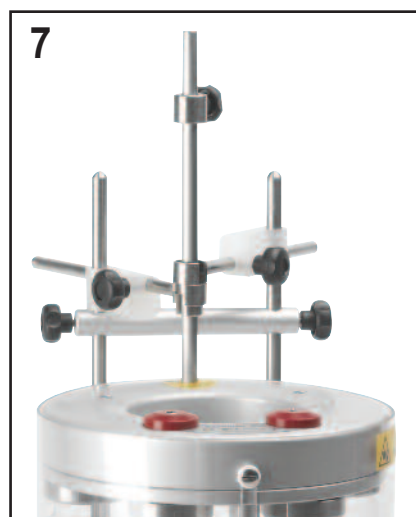

Tighten all knobs on support stand and slide the boss head guide into place.

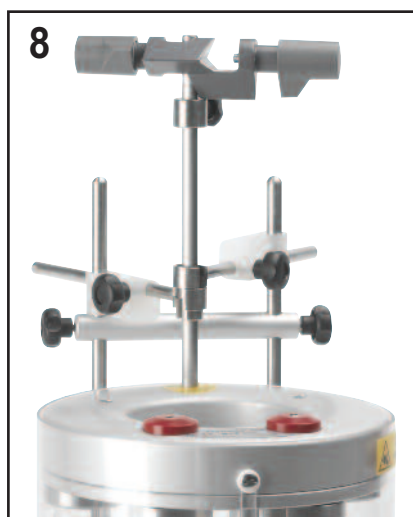

Screw the boss head in place, using the guide collar as an aid to positioning.

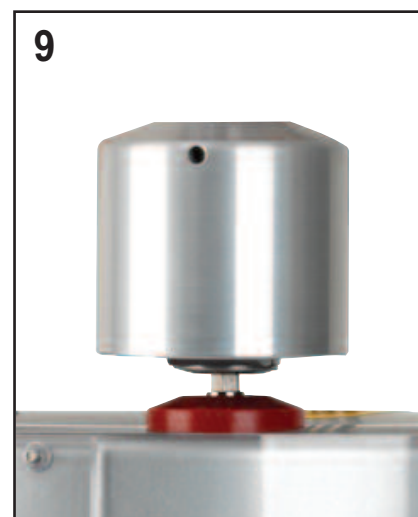

Locate the flexible drive coupling into one of the drive ports.

## 10. Quick Start Guide - continued



**10**  
Locate the overhead stirrer into the boss head and engage chuck on to drive coupling spindle. Tighten chuck.



**11**  
Power up stirrer and run at minimum speed to check general alignment. Adjusting positions as necessary.



**12**  
Raise guard and lock in place by rotating clockwise. Attach gas distribution tubing.



**13**  
Remove the reflux insert in the reflux head by pulling gently on the knob.



**14**  
Assemble the chosen glassware, stirrer and quick-release cap. Charge with sample.



**15**  
Insert the flask assembly into the chosen location. Connect the tubing from the cap to the gas inlet.



**16**  
Replace the reflux insert.

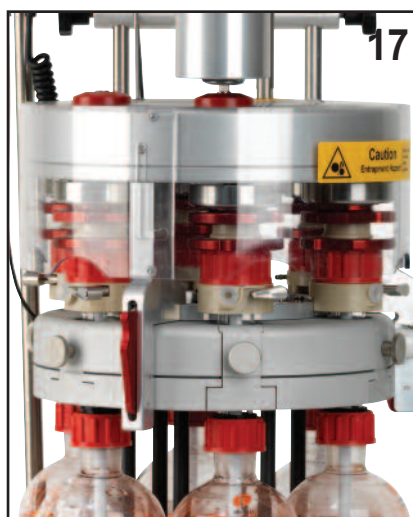

**17**  
Lower guard and lock in place by rotating anti-clockwise.



**18**  
Insert Temperature Controller and attach any accessory glassware. The system is now ready for operation.

# 11. Set-Up & Operation

Important, Important,  
Important, Important,  
Important, Important,  
Important, Important,  
Important, Important,  
Important, Important,

## Important Note

The Tornado Plus can only be used in conjunction with the Carousel 6 Classic and Carousel 6 Plus unit. Using the Tornado Plus on its own may cause damage to the product.



## Warning

The Tornado Plus must be supported by a suitable support stand such as the RR99230 Universal Support Stand or securely clamped to the framework within your fumehood. Under no circumstances should the system be operated without suitable support. It is the responsibility of the user to ensure the suitability of any supporting stand or framework.



### 11.1 Preparing supporting framework and fitting Carousel 6 Plus

Identify a level and clear space within your fumehood to site your Tornado Plus assembly. Moving the assembly after set-up is not recommended so take care to plan your services and connections carefully. You will require two power outlets, cooling water supply for the reflux head and inert gas and vacuum supply if operating under an inert atmosphere.

### 11.2 Set-up the Universal Support Stand (RR99230) or clamping framework

The Tornado Plus is a tall assembly and therefore it is important that it is clamped and supported correctly. Either by use of the Universal Support Stand (RR99230) or by another separate support stand or framework within your fumehood.

Position your stirring hotplate on to the Universal Support Stand or adjacent to your clamping framework.

### 11.3 Locate the Carousel 6 Place on top of the stirring hotplate.

The circular recess in the base of the Carousel unit is designed to fit snugly around the top plate of the stirring hotplate (maximum diameter 135mm).

Important, Important,  
Important, Important,  
Important, Important,  
Important, Important,  
Important, Important,  
Important, Important,

## Important Note

Please read the Carousel 6 Reaction Station instructions in conjunction with these Tornado Plus instructions before operating the system.

Important, Important,  
Important, Important,  
Important, Important,  
Important, Important,  
Important, Important,  
Important, Important,

## Important Note

Always fully read the instructions of any third party equipment, such as overhead stirrers thoroughly, to ensure you are not contravening any safety recommendations or manufacturers warranty when used in conjunction with the Tornado.



## Warning

Do not lift the Carousel 6 by the black PTFE heat protection ring.



## Warning

The Carousel 6 and Tornado Plus should only be used in a fumehood with protective safety sash.

11.2



11.3

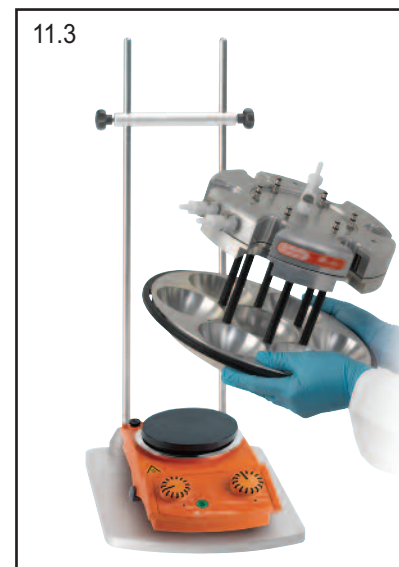

## 11. Set-Up & Operation - continued

### 11.4 Fitting the Tornado

- Screw support rod into threaded hole in top of Tornado (11.4.1) using the spanner provided
- The Tornado's three legs are designed to locate between any pair of Carousel's six vessel positions. Therefore the Tornado can be orientated in any one of 6 positions on top of the Carousel.

Important, Important,  
Important, Important,  
Important, Important,  
Important, Important,  
Important, Important,  
Important, Important,

#### Important Note

If you are using the RS37 Carousel Digital Temperature Controller (RR99237) or a Pt100 probe you will need to ensure that the temperature probe hole in the Carousel 6 is lined up with the two probe holes in the Tornado. Circled in red.



- By firmly placing the Tornado onto a level surface you will ensure that the three red securing clips on each of the Tornado's legs will engage (pop out) ready for fitting (11.4.2).
- Then lift and place the Tornado unit onto the Carousel 6 reaction station (11.4.3). You will need to push down firmly to ensure that the 3 securing clips engage. When the Tornado is correctly mounted you will hear a click and each of the red securing clips will click/locate under the reflux head (11.4.4).
- To remove the Tornado push each of the sprung loaded red securing clips in and down (11.4.5) and then lift the unit.



Important, Important,  
Important, Important,  
Important, Important,  
Important, Important,  
Important, Important,

#### Important Note

The Tornado utilises a small pin on the underside of one of its three legs to locate onto the top of the Carousel 6 Plus reflux head. If this pin is not properly inserted then the Tornado will not mount correctly (11.4.6).

Important, Important,  
Important, Important,  
Important, Important,  
Important, Important,  
Important, Important,

#### Important Note

It is advisable to test the Tornado is correctly located by slightly lifting the complete Tornado and Carousel. But do not carry the Carousel and Tornado assembly by the Tornado alone, always support the Carousel base.

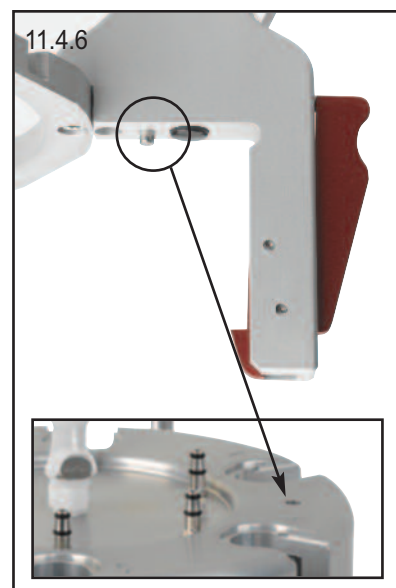
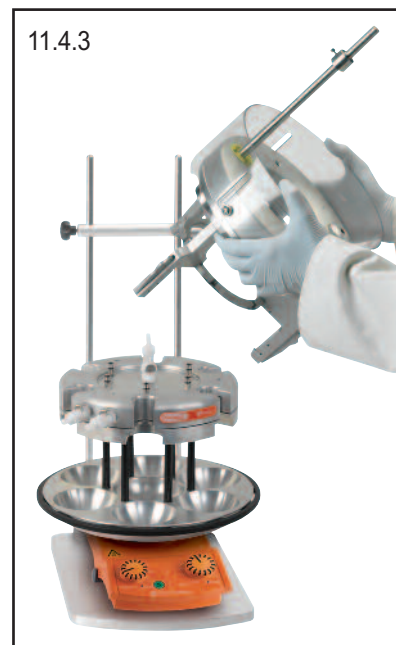
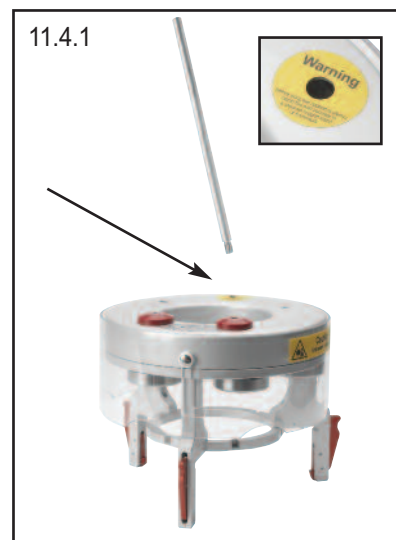

## 11. Set-Up & Operation - continued

### 11.5 Fitting the Universal Support Stand

- Secure cross supports of the Universal Support Stand firmly around the Tornado support rod.
- Tighten all knobs on Universal Support Stand.

Important, Important,  
Important, Important,  
Important, Important,  
Important, Important,  
Important, Important,  
Important, Important,  
Important, Important,

#### Important Note

Assemble Universal Support Stand as per separate instructions.

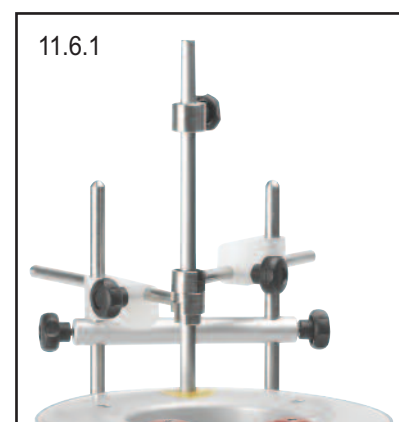
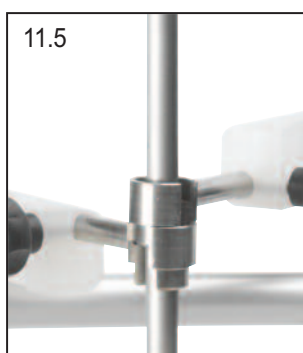

### 11.6 Fitting the overhead stirrer motor

- Slide the boss head guide collar into place. Once you have established the best location for the collar you may wish to mark the support rod with a pen for future (11.6.1).
- Screw the boss head in place, using the guide collar as an aid to positioning (11.6.2).
- Locate the hexagonal end of the flexible drive coupling into one of the drive ports (choose from 1:1 or 2:1). The coupling is designed to compensate for small amounts of misalignment between the overhead stirrer and the Tornado drive port (11.6.3).
- Locate overhead stirrer into the boss head. Locate chuck on to the top of the drive coupling spindle. Tighten chuck and tighten boss head (11.6.4).
- Turn on overhead stirrer and run at slowest speed to check general alignment of assembly. Make any fine adjustments to optimise alignment of stirrer and coupling.

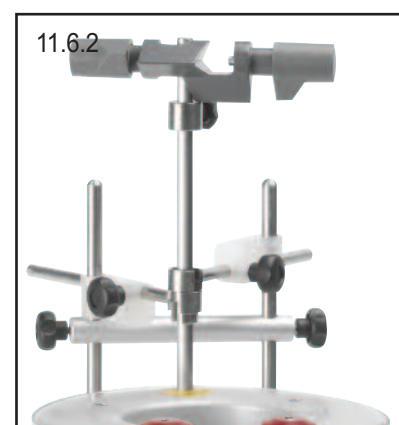

#### 1:1 Drive Port

Has a maximum stirrer input speed of 1,000rpm with an output of 1,000rpm. Suitable for higher speed stirring of lower viscosity solutions.

#### 2:1 Drive Port

Has a maximum stirrer input speed of 1,000rpm with an output of 500rpm. Allows lower rated mechanical stirrers to be used for high viscosity liquids. Maximum viscosity of 10,000cps at 500rpm.

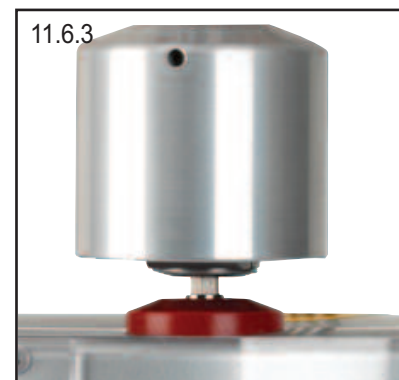

#### Warning

When in operation the Tornado Plus consists of a number of rotating parts. Take care when using this product. The protective guard should always be in the down position during stirring to prevent risk of finger entrapment.



## 11. Set-Up and Operation - Continued

### 11.7 Selection of Glassware

The Tornado Plus is available with a range of unique glassware tailored for the specific requirements of parallel synthesis.

You should select the glassware for your application based on volume, side arm configuration, neck size and if you need baffles or an azeotropic set-up.

For details of the full range see section 9.

### 11.8 Select an appropriate stirring shaft

A range of PTFE stirrer shafts have been designed specifically for the Tornado. The centrifugal stirrer shafts will fit into any one of the Radleys flasks. The larger anchor and propeller stirrer shafts will fit in the new wide neck flasks.

#### Stirrer Shaft Options

Cat No	Description	Pk Qty
A RR99240	Centrifugal PTFE Stirrer Shaft	6
A RR99241	Centrifugal PTFE Stirrer Shaft	1
B RR99244	Anchor PTFE Stir Shaft for 100ml Flasks	6
B RR99245	Anchor PTFE Stir Shaft for 100ml Flasks	1
C RR99248	Anchor PTFE Stir Shaft for 250ml Flasks	6
C RR99249	Anchor PTFE Stir Shaft for 250ml Flasks	1
D RR99251	Propeller PTFE Stirrer Shaft	6
D RR99252	Propeller PTFE Stirrer Shaft	1

### 11.9 Assemble the Reaction Flask and Reflux Tube

All glassware to be used in the Tornado requires a reflux neck. The next step will depend on the glassware you have selected. If you have chosen...

- ...a round bottom flask with an integrated reflux neck - see 11.9.1
- ...a round bottom flask which requires a reflux tube be attached to it - see 11.9.2
- ...a wide neck round bottom flask - see 11.9.3

#### 11.9.1 Glassware with integrated reflux neck

As you have selected glassware with an integral reflux neck you will not need to add a separate reflux tube and can skip directly to step 11.10

#### 11.9.2 Assembling a round bottom flask requiring a reflux neck

You will need to add a reflux tube to your round bottom flask using a Rodaviss® Ground Glass Joint. Rodaviss is an extra-safe borosilicate glass joint for connecting laboratory glassware.

Rodaviss is safe under vacuum or pressure, grease free, interchangeable with standard 1:10 tapered ground joints (including A, B and C lengths), will not stick or jam, is extremely strong and can be used up to 200°C.

Place the cone of the reflux tube through the red connecting cap and then roll the O-Ring up over the cone until it drops past the shoulder of the cone. Clip the black loosening ring between the top of the connecting cap and glass rim on the cone. Insert the cone into the socket on the flask. Screw down the connecting cap onto the thread on the socket to compress the O-Ring, thus ensuring a perfect seal and a rigid assembly.

In the event of any difficulty in undoing the joint because the surfaces are jammed, simply unscrew the connecting cap back onto the loosening ring, which will push the joints easily apart. This system will release even the most 'frozen' joints.

11.8

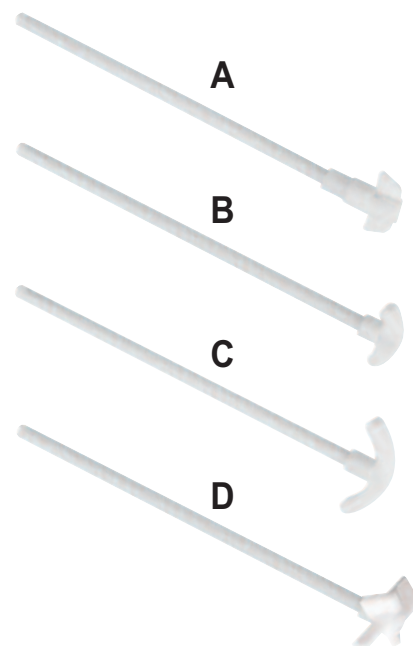

11.9

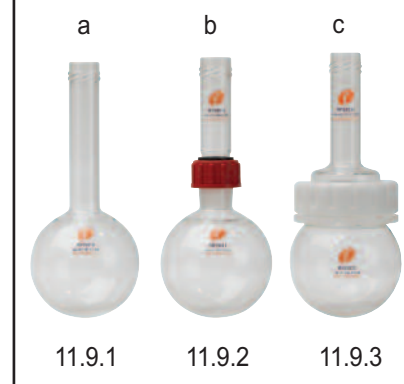

11.9.2





## 11. Set-Up and Operation - Continued

### 11.9.3 Assembling Wide Neck glassware

- Position the Lower Coupling (2) around the neck of the Flask (1) by prising it apart at the open edges and pushing around the neck of the Flask.
- The Nitrile O-Ring (4) fits around the circumference of the Support Collar (3).
- Place the adjoined Support Collar (3) and O-Ring (4) on to the flat flange of the Flask.
- Then place the Reflux Tube (5) on to the Flask and O-Ring assembly. (Note: The Reflux Tube is not held in place until the next step)
- Slide the Upper Coupling (6) over the top of the Reflux Tube (5) and screw onto the Lower Coupling (2).

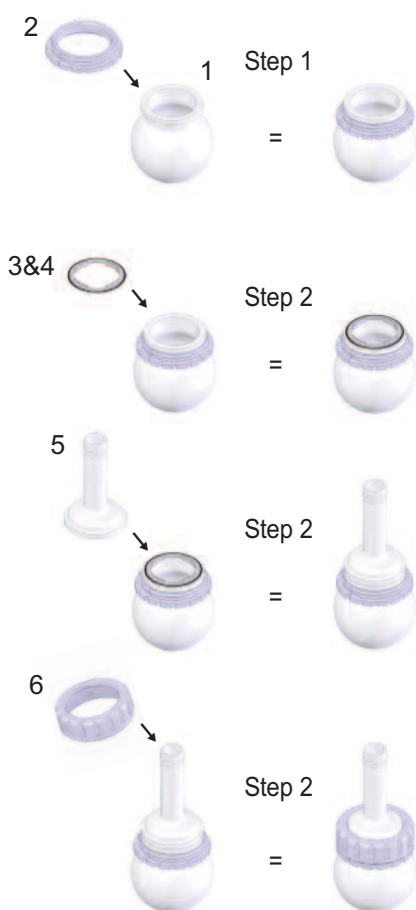

### 11.9.3 Wide Neck Component Guide



### 11.10 Assembling the Quick Thread Stirrer Guide Assembly and stirring shaft

Use the twist action finger release on the top of the stirrer seal/cap to release/unlock the stirrer shaft grip (this is designed to be done with one hand).

Select the stirrer shaft and push the stirrer rod up into the stirrer seal/cap until it stops, (this may be tight as it passes the seal ring inside but keep pushing until it reaches the top inside the cap). Release the twist lock, the stirring shaft is now gripped and ready to use.

### 11.11 Assembling the Quick Thread Stirrer Guide Assembly and flask

Assembling the Stirrer Guide Assembly and flask requires a ¼ turn of the cap, hand tighten until the cap feels secure. Ensure that the flask is properly located within the O-Ring seal in the cap.



#### Warning

Do not over tighten the Stirrer Guide Assembly, as this may damage the cap and fracture the reflux tube.

Important, Important,  
Important, Important,  
Important, Important,  
Important, Important,  
Important, Important,  
Important, Important,

#### Important Note

Please note that the Stirrer Guide Assembly 'seal' on the Nitrile O-Ring before they are fully tightened. Fully tightening the caps will effect a double seal on the PEEK inner of the cap and Nitrile O-Ring.

### 11.10

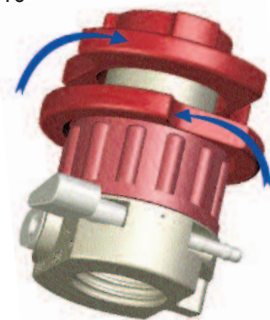

### 11.11



## 11. Set-Up and Operation - continued

### 11.12 Stirrer Seal/Cap

The stirrer guide assembly is designed so that components that come into contact with vapours from the reaction vessel are made of the most suitable chemically resistant materials thereby minimising the risk of chemical attack and prolonging the life of the components. However due to wear and/or chemical attack, periodic replacement of components will be necessary. Therefore always check and clean these components regularly.

### 11.13 Stirrer Seal/Cap Replacement Parts

Cat No	Description	Pk Qty
RR99952	Quick-Thread Stirrer Guide Assembly	1
C RR99271	Peek Slip Ring	1
D RR99272	Sprung Slip Ring (Carbon filled PTFE)	1
E RR99285	Slip Ring Spring	1
F RR99297	Stirrer Seal Circlip - 15.1mm OD	1
G RR99273	PTFE Shaft Seal	1
H RR98076	Replacement Suba-Seal	100
I RR99287	Replacement Viton O-ring for Stirrer Seal/Cap	10

Important, Important,  
Important, Important,  
Important, Important,  
Important, Important,  
Important, Important,  
Important, Important,

#### Important Note

To avoid excessive corrosion always ensure that the six Stirrer Seal/Cap Assemblies are disassembled, cleaned with a suitable non-corrosive solvent and thoroughly dried after use. To minimise corrosion from aggressive vapours these assemblies should also be stored outside of the fumehood when not in use.

Important, Important,  
Important, Important,  
Important, Important,  
Important, Important,  
Important, Important,  
Important, Important,

#### Important Note

Do not attempt to dismantle the stirrer seal/cap beyond the replaceable components indicated above. **THIS WILL INVALIDATE YOUR WARRANTY.** The stirrer seal/cap contains many factory set sub-components that may be difficult for an untrained user to disassemble or reassemble correctly.

### 11.14 Suba-Seal over pressure venting

The Suba-Seal located in the side of the Stirrer seal/cap is not suitable for making additions, as there is no through hole. In this instance the Suba-Seal is being used as a simple venting outlet should pressure within the vessel and cap assembly exceed between 1 and 1.5 bar. This Suba-Seal will require periodic replacement - order Cat No. **RR98076**.



#### Warning

The vessel seal/caps have been fitted with a Suba-Seal that will allow venting should pressure within the vessel and cap assembly exceed between 1 and 1.5 bar.



#### Warning

When applying gas to the Carousel 6 gas inlet system do not exceed 1 (one) psi as the reaction vessels are not rated for pressure, (they are however suitable for applying a vacuum).

Important,  
Important, Important,  
Important, Important,  
Important, Important,  
Important, Important,  
Important, Important,

#### Important Note

The Carousel is not suitable for continuous use under vacuum (e.g. for evaporations or for reactions to be carried out under vacuum) as there is a risk that the vacuum would pull chemicals up through the Carousel reflux head and damage it. Vacuum should only be used intermittently to remove air and replace it with an inert gas. Also, please note that the Carousel is not designed to be fully vacuum tight.

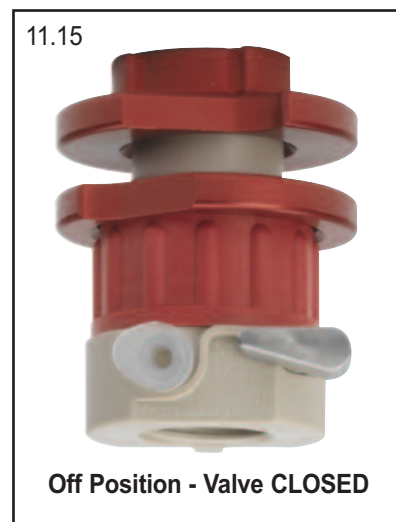
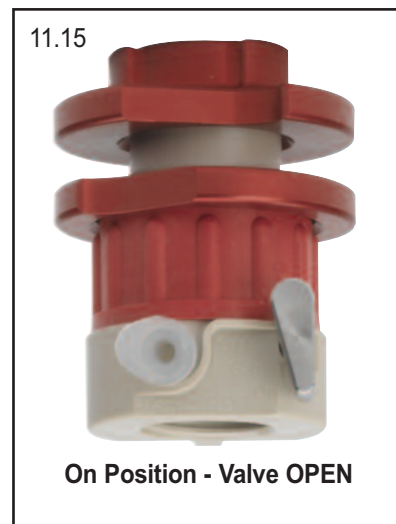
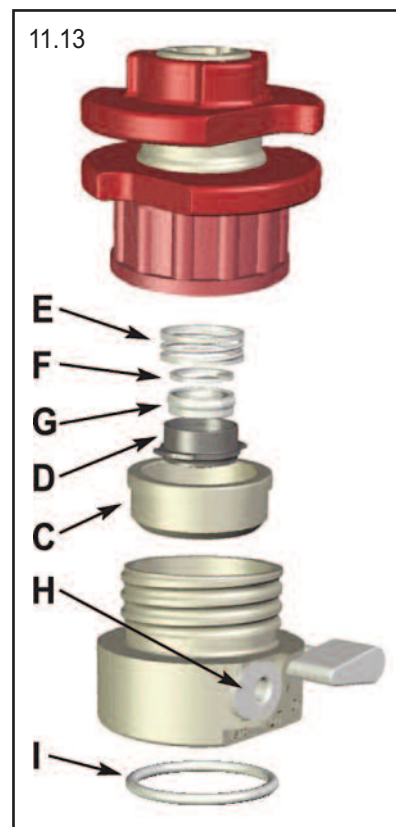

## 11. Set-Up and Operation - continued

### 11.15 On/Off Valve

The on/off valve permits the reaction vessel to be evacuated and purged with inert gas. In the closed position vessel and cap assemblies can be removed and an inert atmosphere maintained within the vessel. To open the inlet turn the key anti-clockwise to the vertical position, where it lines up with the 'On' label. A quarter turn clockwise to the horizontal position will close the valve, sealing and isolating the reaction vessel from the rest of the gas system. (see pictures 11.15 on page 17)

### 11.16 Inserting flasks

- Raise the guard and lock in place by rotating clockwise. (11.16.1)
- At the required location, remove the reflux insert in the reflux head by pulling gently on the knob and sliding outwards. (11.16.2)
- Place the vessel into the Carousel 6 Plus base with the reflux tube leaning out towards you. The Suba-Seal and valve switch should be facing towards you and away from the Tornado. (11.16.3)
- Push the vessel assembly into the reflux head at the same time pushing down gently on the top of the sprung loaded cap to insert it into the corresponding drive port on the underside of the Tornado. If correctly inserted the cap should pop up.
- The stirrer assembly also features a small protrusion (on the side opposite to the Suba-Seal) which slots into a corresponding indent on the lower metal ring of the Tornado. If these are not aligned the assembly will not locate.
- If the vessel and stirrer seal/cap assembly does not fit in first time, check that it is assembled correctly; that the stirrer assembly is screwed on fully and the glass joint is correctly mated. You may also need to try slightly rotating the sprung loaded cap to prevent it from catching on the edge of the Tornado.
- Never force the glassware and always take care to ensure your vessel sidearms are positioned to the front.
- Once in place carefully release the sprung loaded cap and it will locate into the drive port.
- Connect the stirrer guide assembly with the tubing provided to the appropriate radial gas connector on the reflux head (this is best done from above).
- Replace the reflux insert in the reflux head. (11.16.4)
- Any accessory glassware can now be added.
- Repeat the above steps for each flask.
- Once all flasks are loaded lower the guard and lock in place. (11.16.5)

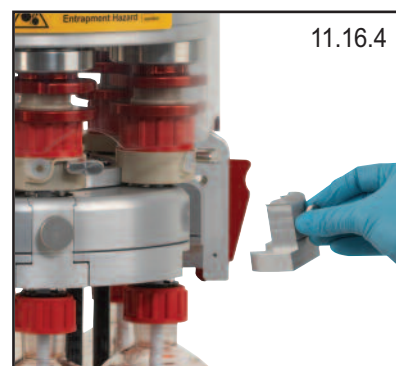

Important, Important,  
Important, Important,  
Important, Important,  
Important, Important,  
Important, Important,  
Important, Important,

#### Important Note

If inserting flasks smaller than 250ml the appropriate aluminium insert must now be inserted to ensure maximum heat transfer. 250ml flasks do not require the use of an aluminium insert.



## 11. Set-Up and Operation - continued

### 11.17 Connect Gas/Vacuum supply

- The central gas inlet and radial distribution system combined with gas tight stirrer assembly allows reactions to be performed under an inert (nitrogen/argon) atmosphere.
- For use under an inert atmosphere attach tubing to the central quick-release coupling and connect via a 3-way tap or stopcock to a vacuum source and inert gas supply (recommended maximum pressure 1psi).
- Then, by alternately evacuating the system and filling it with a suitable inert gas (repeating 2 to 3 times) will achieve an inert atmosphere within the flasks.
- The Reaction Flasks can be isolated or removed during synthesis by simply closing the valve on the Stirrer Guide Assembly, detaching the gas tubing and removing the flask.
- This can be done before or after the flasks are loaded.



#### Warning

When applying gas to the reaction station gas inlet system do not exceed 1 (one) psi as the Reaction Flasks and stirrer assemblies are not rated for pressure, (they are however suitable for applying a vacuum).

Important,  
Important, Important,  
Important, Important,  
Important, Important,  
Important, Important,  
Important, Important,  
Important, Important,

#### Important Note

The Carousel is not suitable for continuous use under vacuum (e.g. for evaporations or for reactions to be carried out under vacuum) as there is a risk that the vacuum would pull chemicals up through the Carousel reflux head and damage it. Vacuum should only be used intermittently to remove air and replace it with an inert gas. Also, please note that the Carousel is not designed to be fully vacuum tight.

### 11.18 Stainless Steel Gas Outlets

The stainless steel Gas Outlets on top of the reflux head feature an upper and lower Nitrile O-Ring as standard, an optional Viton replacement is available.

These O-Rings may be subject to chemical attack and will require periodic replacement.

- RR91060 Nitrile O-Rings 4mm Gas Outlet - Bottom, pk 50
- RR91061 Nitrile O-Rings 3mm Gas Outlet - Top, pk 50
- RR91062 Viton O-Rings 4mm Gas Outlet - Bottom, pk 50
- RR91063 Viton O-Rings 3mm Gas Outlet - Top, pk 50

### 11.19 Unused positions

If all Gas Outlets are not in use, unused outlets can be blocked off with an inverted Silicone Septa.

### 11.20 Connecting the coolant supply

Use of water/coolant in the reflux head is essential to maintain satisfactory refluxing to minimise solvent loss and prevent escape of volatile reagents. Use of a refrigerated recirculating chiller will further reduce solvent losses.

Connect the quick release inlet and outlet to a suitable water (or other circulating coolant) supply and drain respectively, ensuring enough tubing is available for easy rotation of the Carousel. Both the male and female quick release fittings feature a non-return shut-off valve.

High Pressure water/coolant supplies should not be used.

Important, Important,  
Important, Important,  
Important, Important,  
Important, Important,  
Important, Important,  
Important, Important,  
Important, Important,

#### Important Note

Liquid coolants other than water can be used in the reflux head, but the use of silicone based coolants, for example silicone oils, should be avoided as these will cause damage to internal components of the reflux head.

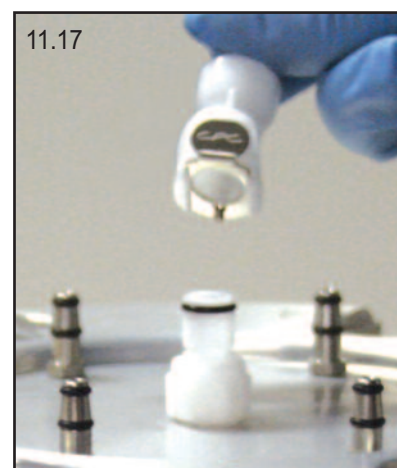

## 11. Set-Up and Operation - continued

### 11.21 Running the Tornado

As the overhead stirring motor is a proprietary part, the normal instructions for the motor you are using will apply.

If the motor you are using is capable of very high speeds then take note that the Tornado Plus is specified to run at a maximum of 1,000rpm and speeds above this may cause the unit to fail prematurely.

Ensure the protective clear plastic guard is in the down position during stirring to prevent risk of finger entrapment.

Before commencing your experiment, turn on overhead stirrer and run at slowest speed to check general alignment of assembly. Make any fine adjustments to optimise alignment of stirrer and coupling.



Important, Important,  
Important, Important,  
Important, Important,  
Important, Important,  
Important, Important,  
Important, Important,

#### Important Note

Maximum recommended stirring speed is 1000 rpm.

Important, Important,  
Important, Important,  
Important, Important,  
Important, Important,  
Important, Important,  
Important, Important,

#### Important Note

Please read the separate Carousel Stirring Hotplate instructions thoroughly before operation.

Important, Important,  
Important, Important,  
Important, Important,  
Important, Important,  
Important, Important,  
Important, Important,

#### Important Note

Maximum recommended operating temperature is 180 °C, however block temperatures of 220 °C can be achieved.

Important, Important,  
Important, Important,  
Important, Important,  
Important, Important,  
Important, Important,  
Important, Important,

#### Important Note

Always ensure that the temperature sensor is completely immersed into the liquid when inserted into the Reaction Flask.

Important, Important,  
Important, Important,  
Important, Important,  
Important, Important,  
Important, Important,  
Important, Important,

#### Important Note

Care should be taken to monitor the total set up during synthesis, paying particular attention to regularly check the inert gas supply, flow of cooling water to the reflux head and reaction temperature and make adjustments as necessary.

## 11. Set-Up and Operation - continued

### 11.23 Once your synthesis is complete

- Turn off heating.
- Turn off overhead stirrer.
- Turn off gas supply.
- Disconnect gas inlet.
- Once the reaction has sufficiently cooled, turn off reflux cooling.
- The Reaction Flasks can now be removed.

### 11.24 Removing the Tornado from the Carousel 6

Firstly remove all flasks, stirring motor and clamps from the Carousel and Tornado.

To remove the Tornado from the Carousel 6, push each of sprung loaded red securing clips in and down (11.24.1). The unit is now ready to lift off of the Carousel.

The red securing clips will reset when the Tornado is placed onto a flat surface. This resets the securing clips ready for re-attachment to the Carousel with no further adjustment necessary.

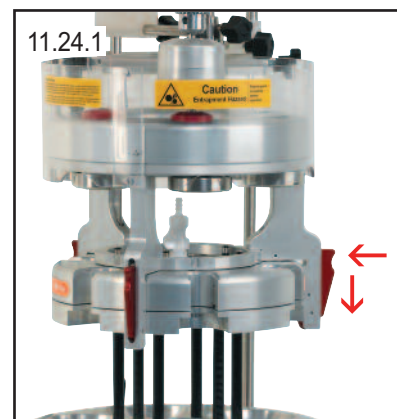

Important, Important,  
Important, Important,  
Important, Important,  
Important, Important,  
Important, Important,  
Important, Important,  
Important, Important,

#### Important Note

Please read the Carousel 6 Plus Reaction Station instructions in conjunction with these Tornado Plus instructions before operating the system.

Important, Important,  
Important, Important,  
Important, Important,  
Important, Important,  
Important, Important,  
Important, Important,  
Important, Important,

#### Important Note

Always read the instructions of any third party equipment, such as overhead stirrers thoroughly, to ensure you are not contravening any safety recommendations or manufacturers warranty when used in conjunction with the Tornado.



#### Warning

When in operation the Tornado Plus consists of a number of rotating parts. Take care when using this product. The protective guard should always be in the down position during stirring to prevent risk of finger entrapment.



#### Warning

The Carousel 6 and Tornado Plus should only be used in a fumehood with protective safety sash.



## 12. Maintenance and Servicing

### 12.1 Important Cleaning and Maintenance Checks

The Tornado Plus contains moving parts that will wear and/or corrode over time, and this is particularly the case where aggressive solvents or solvent vapours are present. Periodic servicing of your machine and the replacement of these parts is recommended. Please contact your local Radleys distributor for further information about servicing options.

Regular checks of all seals, bearing, belts and moving parts etc and thorough cleaning after each use will help to extend the life of your unit.

### 12.2 Parts that can wear

There are two main areas where wear and/or corrosion may occur, these are the **Drive Belt** and the seals and bearings within the **Stirrer Seal/Cap Assemblies**.

### 12.3 Cleaning and maintenance tips

- Keep the surfaces of the Tornado clean from chemical spills. Although the surfaces are designed to resist most chemicals, some chemicals or vapours may cause staining or discolouration of the surfaces.
- To avoid excessive corrosion always ensure that the Stirrer Seal/Cap Assemblies are disassembled, cleaned with a suitable non-corrosive solvent such as IMS and thoroughly dried after use.
- The best way to ensure that the Stirrer Seal/Cap Assemblies are thoroughly dry after cleaning is to use hot air or place in a drying cabinet.
- To minimise corrosion from aggressive vapours the Stirrer Seal/Cap Assemblies should also be stored outside of the fumehood when not in use.
- Check the Viton O-ring periodically, these o-rings will breakdown over time if the chemistry is harsh, replace if you see signs of cracking.

### 12.4 Replacing the Drive Belt

This is where the power from the stirrer motor is transmitted to the 6 vessels. Over extended periods of running it is possible that the belt could wear and possibly break.

#### 12.4.1 To check or replace the belt

- Remove the top of the Tornado by first removing the 2 screws underneath the main top of the drive.
- Lift off the top ring, this may be tight due to the seals that are fitted to seal the top.
- You can now see the belt. If it looks worn then replace it. To do this:
  - Pull back the belt tensioner, it will lock out
  - Lift off the belt
  - Fit the new belt; make sure it fits around all of the pulleys loosely.
  - Lift the pin on the tensioner and it will click back into position.
  - Move the belt around by hand to check that it is running smoothly.
- Replace the top ring.
- Re-fit the 2 screws underneath the main top of the drive.

Important, Important,  
Important, Important,  
Important, Important,  
Important, Important,  
Important, Important,  
Important, Important,  
Important, Important,

#### Important Note

Do not attempt to dismantle the Stirrer Seal/Cap Assembly beyond the replaceable components indicated overleaf.



Cover removed showing drive belt and internal drive set-up



Tensioner in the release position to allow removal of the drive belt

## 12. Maintenance and Servicing - continued

### 12.4.2 Replacement Parts

Cat No	Description	Pk Qty
RR99274	Drive Belt	1
RR99275	Belt Roller Bearing	1

Important, Important,  
Important, Important,  
Important, Important,  
Important, Important,  
Important, Important,  
Important, Important,  
Important, Important,

#### Important Note

Servicing should always be carried out by a trained and competent person.

### 12.5 Replacing the Seals in the Stirrer Seal/Cap Assembly

The stirrer seal/cap assembly contains moving parts that will wear and/or corrode over time, and this is particularly the case where aggressive solvents or solvent vapours are present. Periodic servicing of your assemblies and the replacement of these parts is recommended. Therefore always check and clean these components regularly.

Important, Important,  
Important, Important,  
Important, Important,  
Important, Important,  
Important, Important,  
Important, Important,  
Important, Important,

#### Important Note

Do not attempt to dismantle the stirrer seal/cap beyond the replaceable components indicated below. THIS WILL INVALIDATE YOUR WARRANTY. The stirrer seal/cap contains many factory set sub-components that may be difficult for an untrained user to disassemble or reassemble correctly.

Please contact your local Radleys distributor for further information about servicing options where replacement of these parts may be necessary.

#### 12.5.1 Stirrer Seal/Cap Replacement Parts

Cat No	Description	Pk Qty
RR99952	Quick-Thread Stirrer Guide Assembly	1
<b>C</b> RR99271	Peek Slip Ring	1
<b>D</b> RR99272	Sprung Slip Ring (Carbon filled PTFE)	1
<b>E</b> RR99285	Slip Ring Spring	1
<b>F</b> RR99297	Stirrer Seal Circlip - 15.1mm OD	1
<b>G</b> RR99273	PTFE Shaft Seal	1
<b>H</b> RR98076	Replacement Suba-Seal	100
<b>I</b> RR99287	Replacement Viton O-ring for Stirrer Seal/Cap	10

#### 12.5.2 To check or replace the seals within the stirrer seal/cap assembly:

**12.5.2** Open the assembly by holding the Peek (tan coloured) base and unscrewing the red Rodaviss connecting cap. The assembly will split into two parts.

**12.5.2** Inspect the running surfaces or the tan coloured Peek Slip Ring (**C**), the black (Carbon filled PTFE) Sprung Slip Ring (**D**) and the inner surface of the white PTFE Shaft Seal (**G**).

**12.5.2** If they are worn or discoloured then replace them. To do this:

Hold the black Sprung Slip Ring (**D**) and rotate it clockwise to release it from its holder. A spring (**E**) may pop out with this part.

If the black Sprung Slip Ring (**D**) is ok and only the PTFE Shaft Seal (**G**) needs replacing, use Circlip pliers to carefully remove the Stirrer Seal Circlip (**F**). Then you should be able to remove and replace the PTFE Shaft Seal (**G**). You may need a small pin to pop this out.

Fit a replacement PTFE Shaft Seal (**G**) in to the black Sprung Slip Ring (**D**), re-insert the Stirrer Seal Circlip (**F**)

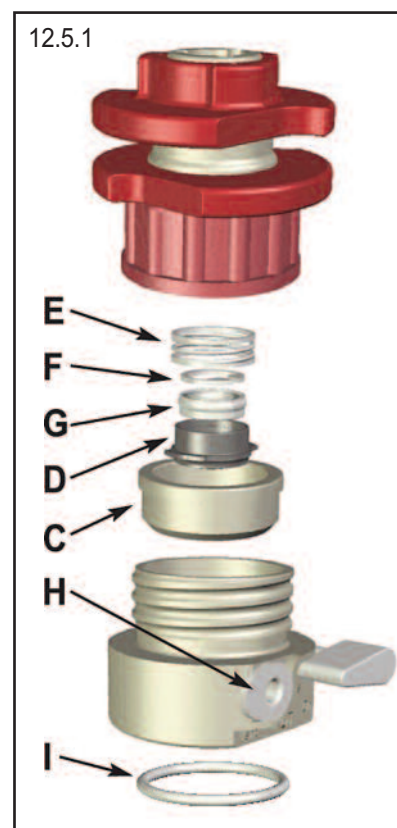
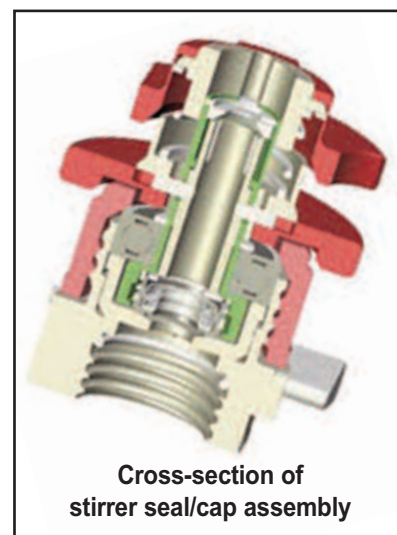
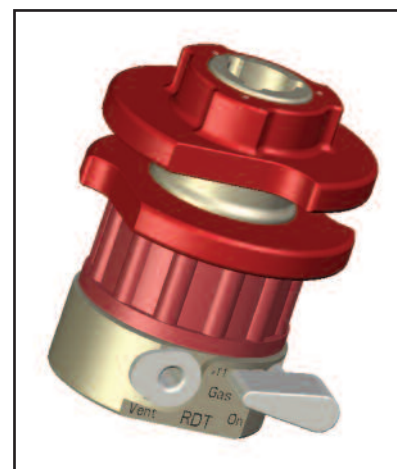



## 12. Maintenance and Servicing - continued

### 12.5.2 Continued

To re-fit the Sprung Slip Ring (D) back in its holder, rotate it anti-clockwise (making sure the Slip Ring Spring (E) has been refitted)

Remove the Peek Slip Ring (C) from the Peek base and fit a new one.

Re-fit the two assembly parts together by re-fitting and re-tightening the red Rodaviss connecting cap onto the Peek base.

### 12.6 Cleaning and maintenance tips

**12.5.2** Keep the surfaces of the Tornado clean from chemical spills. Although the surfaces are designed to resist most chemicals, some chemicals or vapours may cause staining or discolouration of the surfaces.

**12.5.2** To avoid excessive corrosion over time always ensure that the Stirrer Seal/Cap Assemblies are disassembled, cleaned with a suitable non-corrosive solvent such as IMS and thoroughly dried after use.

**12.5.2** The best way to ensure that the Stirrer Seal/Cap Assemblies are thoroughly dry after cleaning is to use hot air or place in a drying cabinet.

**12.5.2** To minimise corrosion from aggressive vapours the Stirrer Seal/Cap Assemblies should also be stored outside of the fumehood when not in use.

**12.5.2** Check the Viton O-ring periodically, these o-rings will breakdown over time if the chemistry is harsh, replace if you see signs of cracking.

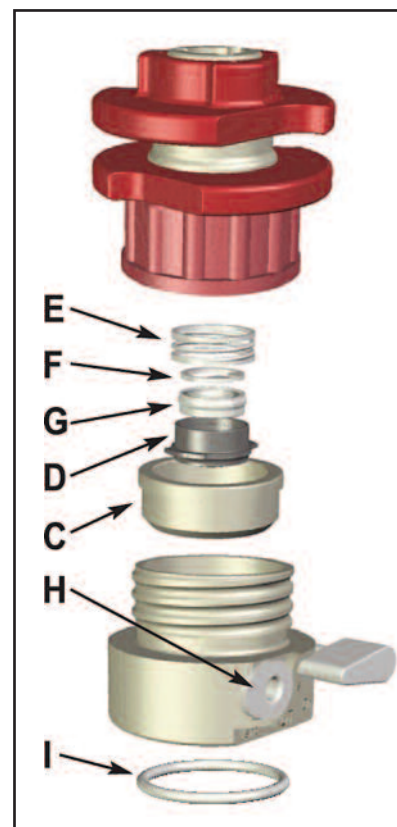

# Warranty – Email Back

## sales@radleys.co.uk

To qualify for your warranty please complete, scan and email this form to Radleys

Date of Purchase .....	
Supplier's Name and Address .....	
Product Batch/Serial No. (if shown) .....	
<b>Your Details</b>	
Mr   Mrs   Miss   Ms   Dr   Prof	
Name .....	
Position .....	
Dept .....	Building .....
Organisation .....	
Address 1 .....	
Address 2 .....	
Town/City .....	County/State .....
Country .....	Post/Zip Code .....
Telephone .....	Ext ..... Fax .....
Email .....	Website .....

<b>Type of Organisation; please tick all boxes relevant</b>					
<input type="checkbox"/> Academic Institution	<input type="checkbox"/> Consumer Goods	<input type="checkbox"/> Defence/Military/Forensic	<input type="checkbox"/> Government	<input type="checkbox"/> Manufacturing/Industrial	<input type="checkbox"/> Polymers/Plastics
<input type="checkbox"/> Animal Health/Zoology	<input type="checkbox"/> Contract Lab	<input type="checkbox"/> Environmental/Water	<input type="checkbox"/> Hospital/Pharmacy	<input type="checkbox"/> Nuclear/Gas/Electric	<input type="checkbox"/> Process Engineering
<input type="checkbox"/> Agrochemical	<input type="checkbox"/> Contract Synthesis	<input type="checkbox"/> Flavours/Fragrances	<input type="checkbox"/> Instrum/Elect & Mech	<input type="checkbox"/> Petrochemical/Oil	<input type="checkbox"/> Research Institute
<input type="checkbox"/> Chemical Manufacture	<input type="checkbox"/> Cosmetics	<input type="checkbox"/> Food/Beverages	<input type="checkbox"/> Lab Equip Dealer/Mnf	<input type="checkbox"/> Pharma/Biotech/API	<input type="checkbox"/> Other.....
<b>Areas of Interest; please tick all boxes relevant</b>					
<input type="checkbox"/> Analytical Chemistry	<input type="checkbox"/> Chromatography	<input type="checkbox"/> Estate & Facilities	<input type="checkbox"/> Health & Safety	<input type="checkbox"/> Organic Chemistry	<input type="checkbox"/> QC/QA
<input type="checkbox"/> Automation/HTS	<input type="checkbox"/> Clinical/Medical/Pathology	<input type="checkbox"/> Food & Agriculture	<input type="checkbox"/> Inorganic/Metallurgy	<input type="checkbox"/> Parallel Chem/Combi-Chem	<input type="checkbox"/> Sales & Marketing
<input type="checkbox"/> Biochemistry	<input type="checkbox"/> Construction	<input type="checkbox"/> Formulation	<input type="checkbox"/> Liquid Handling/MicroPlates	<input type="checkbox"/> Polymers & Oils	<input type="checkbox"/> Separation/SPE
<input type="checkbox"/> Biological Sciences	<input type="checkbox"/> Drug Discovery	<input type="checkbox"/> Geology	<input type="checkbox"/> Material Science	<input type="checkbox"/> Process Dev/Scale-up	<input type="checkbox"/> Support/Engineering
<input type="checkbox"/> Catalysis	<input type="checkbox"/> Environmental Health	<input type="checkbox"/> Glassblower	<input type="checkbox"/> Medical Devices	<input type="checkbox"/> Process Safety/Calorimetry	<input type="checkbox"/> Temperature Control
<input type="checkbox"/> Other.....	<input type="checkbox"/> Medicinal Chemistry	<input type="checkbox"/> Purchasing/Stores	<input type="checkbox"/> Veterinary		

To request specific product information from Radleys please fill in below

<b>Benchtop and Hotplates</b> <input type="checkbox"/> Findenser Air Condenser <input type="checkbox"/> Heat-On Block System <input type="checkbox"/> Cool-It Insulated Bowls <input type="checkbox"/> StarFish Work Station <input type="checkbox"/> Carousel Stirring Hotplates <input type="checkbox"/> Overhead Stirrers  <b>Jacketed Lab Reactors</b> <input type="checkbox"/> Reactor-Ready Lab Reactor <input type="checkbox"/> Reactor-Ready Duo Lab Reactor <input type="checkbox"/> Reactor-Ready Pilot Lab Reactor <input type="checkbox"/> Custom Jacketed Reaction Systems	<b>Parallel Reaction Stations</b> <input type="checkbox"/> Carousel 12 Plus Reaction Station <input type="checkbox"/> Cooled Carousel 12 Reaction Station <input type="checkbox"/> Carousel 6 Plus Reaction System <input type="checkbox"/> Cooled Carousel 6 Plus Reaction Station <input type="checkbox"/> Carousel Work-Up Station <input type="checkbox"/> GreenHouse Plus Parallel Synthesiser <input type="checkbox"/> GreenHouse Work-Up Station <input type="checkbox"/> GreenHouse Blowdown Evaporator <input type="checkbox"/> Tornado Overhead Stirring System <input type="checkbox"/> Breeze Heating/Cooling Work Station <input type="checkbox"/> Storm Heating/Cooling Work Station	<b>Software</b> <input type="checkbox"/> AVA Lab Control Software <input type="checkbox"/> Level 1/2 <input type="checkbox"/> Level 3/4 <input type="checkbox"/> Data Hub  <b>Automated Reaction Stations</b> <input type="checkbox"/> Mya 4 Reaction Station  <b>Other</b> <input type="checkbox"/> Huber..... <input type="checkbox"/> Heidolph..... <input type="checkbox"/> Other.....
---	---	--