

# Manual

## Knife Mill GM 200

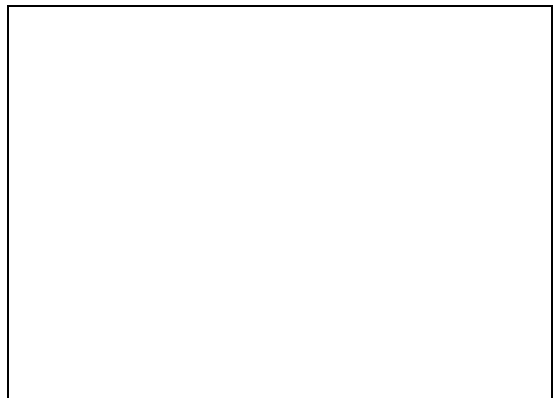

Translation



**Copyright**

© Copyright by  
Retsch GmbH  
Retsch-Allee 1-5  
42781 Haan  
Germany

## Table of Contents

<b>1</b>	<b>Notes on the manual</b> .....	<b>6</b>
1.1	Explanation of signs and symbols .....	6
1.2	Disclaimer .....	6
1.3	Copyright.....	6
<b>2</b>	<b>Safety</b> .....	<b>7</b>
2.1	Explanations of the Safety Instructions .....	8
2.2	General Safety Instructions .....	9
2.3	Repairs.....	10
2.4	Intended use of the device.....	11
2.5	Improper use.....	11
2.6	Confirmation Form for the Managing Operator.....	11
<b>3</b>	<b>Technical Data</b> .....	<b>14</b>
3.1	Protective Equipment.....	14
3.2	Degree of Protection.....	14
3.3	Emissions.....	14
3.4	Electromagnetic Compatibility (EMC).....	15
3.5	Rated Power .....	15
3.6	Motor Rotation Speed.....	15
3.7	Dimensions and Weight.....	15
3.8	Required Floor Space.....	15
3.9	Receptacle Volume.....	16
3.10	Feed Grain Size.....	16
<b>4</b>	<b>Packaging, Transport and Installation</b> .....	<b>17</b>
4.1	Packaging .....	17
4.2	Transport.....	17
4.3	Temperature Fluctuations and Condensation .....	18
4.4	Conditions for the Installation Site .....	18
4.5	Electrical Connection .....	19
4.6	Type Plate Description.....	19
<b>5</b>	<b>First Commissioning</b> .....	<b>21</b>
<b>6</b>	<b>Operating the Device</b> .....	<b>22</b>
6.1	Principle of Operation .....	23
6.2	Views of the device .....	24
6.2.1	Front.....	24
6.2.2	Back .....	25
6.3	Switching On / Off.....	26
6.4	Opening and Closing of the Device .....	26
6.4.1	Opening .....	26
6.4.2	Closing.....	26
6.5	Inserting the Grinding Container.....	27
6.6	Inserting the Knife Insert .....	28
6.7	Filling the Grinding Container .....	29
6.7.1	Filling within the Device .....	29
6.7.2	Filling outside the Device.....	29
6.8	Closing the Grinding Container.....	30
6.9	Full-Metal Knife.....	32
6.9.1	Blade Protection .....	33
6.9.2	Cleaning the Full-Metal Knife.....	34
<b>7</b>	<b>Grinding by means of cold grinding</b> .....	<b>34</b>
7.1	Minimising wear to the blade and achieving good homogenisation results .....	34
7.2	Risk of injury to eyes and skin due to severe frostbite .....	35
7.3	Corrugated grinding jars for improved mixing of the sample.....	35

---

<b>8</b>	<b>Controlling the Device</b>	<b>37</b>
8.1	Operating Controls, Displays and Functions	37
8.2	Operating Modes and Navigation	39
8.2.1	Navigation between Operating Modes	39
8.3	Grinding Parameters	39
8.3.1	Adjustable Parameters	39
8.3.2	Activatable or Deactivatable Parameters	41
8.4	Manual Mode	42
8.4.1	Start Process	42
8.4.2	Stop Process	43
8.5	Programme Mode	43
8.5.1	Select a Program	43
8.5.2	Edit a Program	45
8.5.3	Save a Programme	45
8.5.4	Delete a Programme	45
8.6	Sequence Mode	45
8.6.1	Select a Sequence	46
8.6.2	Edit a Sequence	47
8.6.3	Save a Sequence	47
8.6.4	Delete a Sequence	47
8.7	Settings	47
8.7.1	myRetsch	49
8.7.2	Remote	49
8.7.3	Brightness	50
8.7.4	Software Versions	50
8.7.5	Operating Hours	50
8.7.6	Software Update	50
8.7.7	Service Environment	51
<b>9</b>	<b>Error Messages and Information Notes</b>	<b>52</b>
9.1	Error Messages	52
9.2	Information Notes	53
<b>10</b>	<b>Return for Service and Maintenance</b>	<b>54</b>
<b>11</b>	<b>Cleaning, Wear and Maintenance</b>	<b>55</b>
11.1	Cleaning	55
11.1.1	Cleaning the Grinding Set	56
11.2	Wear	56
<b>12</b>	<b>Maintenance</b>	<b>57</b>
<b>13</b>	<b>Accessories</b>	<b>59</b>
<b>14</b>	<b>Disposal</b>	<b>60</b>
<b>15</b>	<b>Index</b>	<b>61</b>



# 1 Notes on the manual

This manual provides technical guidelines for the safe operation of the device. Read this manual through carefully before installing, putting into service and operating the device. Reading and understanding this manual is essential for handling the device safely and as intended.

This manual does not contain any repair instructions. Please contact your supplier or contact Retsch GmbH directly if anything is unclear or you have questions about these guidelines or the device, or in the case of any faults or necessary repairs.

You can find further information about your device at <https://www.retsch.com> on the pages for the specific device concerned.

**Amendment status:**

The document amendment 0002 of the "Knife Mill GM 200" manual has been prepared in accordance with the Machinery Directive 2006/42/EC.

## 1.1 Explanation of signs and symbols

In this document the following **signs and symbols** are being used:

①	Reference to a recommendation and/or an important information
→	Reference to a chapter, table or figure
⇒	Action instruction
Name	Software menu function
[Name]	Software button
<Name>	Software checkbox

## 1.2 Disclaimer

This manual has been prepared with great care. We reserve the right to make technical changes. We assume no liability for personal injuries resulting from the failure to follow the safety information and warnings in this manual. No liability will be assumed for damage to property resulting from the failure to follow the information in this manual.

## 1.3 Copyright

This document or parts of it or its content may not be reproduced, distributed, edited or copied in any form without prior written permission of Retsch GmbH. Damage claims shall be asserted in the case of infringements.

## 2 Safety

### **Safety Officer**

The operating company itself must ensure the following with respect to persons authorised to work on the device:

- that they have read and understood all regulations contained in the chapter on safety;
- that they are aware before they start work of all instructions and regulations for the target group related to the work;
- that they have easy access to the manual for this device at all times;
- that they have been familiarised with the safe and correct handling of the device before starting work on it, by means of a verbal introduction by a competent person and/or using this manual.

**⚠** Improper operation can lead to personal injuries. The operating company itself is responsible for its safety and that of its staff. The operating company itself must ensure that no unauthorised persons have access to the device.

### **Target group**

All those operating, cleaning or working with or on the device.

This device is a modern, powerful product from Retsch GmbH and has been developed in line with the state-of-the art. The device is safe to use when operated correctly and when following the instructions in this manual.

**⚠** People under the influence of intoxicating substances (medications, drugs, alcohol) or who are overtired may not operate the device or work on the device.

## 2.1 Explanations of the Safety Instructions

The following **warnings** in this manual warn of possible risks and damage:

<b>⚠ DANGER</b>	<small>D1.0000</small>
<p><b>Risk of fatal injuries</b> Source of danger</p> <ul style="list-style-type: none"> <li>– Possible consequences if the danger is ignored.</li> <li>• <b>Instructions and information on how to avoid the risk.</b></li> </ul>	

**Fatal or serious injuries** may result if the “Danger” sign is disregarded. There is a **very high risk** of a life-threatening accident or lasting personal injury. The signal word **⚠ DANGER** is additionally used in the running text or in instructions.

<b>⚠ WARNING</b>	<small>W1.0000</small>
<p><b>Risk of life-threatening or serious injuries</b> Source of danger</p> <ul style="list-style-type: none"> <li>– Possible consequences if the danger is ignored.</li> <li>• <b>Instructions and information on how to avoid the risk.</b></li> </ul>	

**Life-threatening or serious injuries** may result if the “Warning” sign is disregarded. There is an **increased risk** of a serious accident or of a possibly fatal personal injury. The signal word **⚠ WARNING** is additionally used in the running text or in instructions.

<b>⚠ CAUTION</b>	<small>C1.0000</small>
<p><b>Risk of injuries</b> Source of danger</p> <ul style="list-style-type: none"> <li>– Possible consequences if the danger is ignored.</li> <li>• <b>Instructions and information on how to avoid the risk.</b></li> </ul>	

**Average to slight injuries** may result if the “Caution” sign is disregarded. There is an average or slight risk of an accident or personal injury. The signal word **⚠ CAUTION** is additionally used in the running text or in instructions.



## NOTICE

N1.0000

### Type of damage to property

Source of the damage to property

- Possible consequences if the information is ignored.
- **Instructions and information on how to avoid the damage to property.**

**Damage to property** may result if the information is disregarded. The signal word **NOTICE** is additionally used in the running text or in instructions.

## 2.2 General Safety Instructions

### CAUTION

C2.0002

#### Risk of injury

Lack of knowledge of the manual

- The manual contains all safety-related information. Disregarding the manual can therefore lead to injuries.
- **Read the manual carefully before operating the device.**



### CAUTION

C3.0015

#### Risk of injury

Improper modifications to the device

- Improper modifications to the device can result in injuries.
- **Do not make any unauthorised changes to the device.**
- **Only use the spare parts and accessories approved by Retsch GmbH!**

## NOTICE

N2.0012

### Changes to the device

Improper modifications

- The conformity declared by Retsch GmbH with the European Directives will lose its validity.
- Any warranty claims will be terminated.
- **Do not make any modification to the device.**
- **Use spare parts and accessories that have been approved by Retsch GmbH exclusively.**



## 2.3 Repairs

This manual does not contain any repair instructions. For safety reasons, repairs may only be carried out by Retsch GmbH or an authorised representative or by qualified service technicians.

**In case of repair, please inform...**

- ...the Retsch GmbH representative in your country,
- ...your supplier, or
- ...Retsch GmbH directly.

**Service address:**

## 2.4 Intended use of the device

The Knife Mill GM 200 is a laboratory device that has been designed for the grinding and homogenisation of soft to medium-hard materials. Dry materials and those containing water can similarly be processed, as can greasy, oily or fibrous materials.

Examples of different materials:

- Pharmaceutical products (soap, sugar-coated tablets)
- Animal feedstuffs (pellets, cereals)
- Fresh food (fish, meat, vegetables, lettuce)
- Plant parts
- Processed food (cheese, spices, ham, cold meats)
- Confectionary
- Oily materials (cocoa nibs, nuts, oilseeds)
- Frozen foods
- Dry fruit and dietary supplements

This laboratory machine has been designed for operation in an 8-hour single shift, switched on for a 30 % duty cycle .

Only grinding jars and blade inserts from Retsch GmbH may be used.

## 2.5 Improper use

The Knife Mill GM 200 may not be used as a production machine or for continuous operation. This machine is not suitable for the mixing or homogenisation of liquids with low viscosity (emulsions and suspensions) or for cryogenic grinding with liquid nitrogen.

## 2.6 Confirmation Form for the Managing Operator

This manual contains essential instructions for operating and maintaining the device which must be strictly observed. It is essential that they be read by the user and by the qualified staff responsible for the device before the device is commissioned. This manual must be available and accessible at the place of use at all times.

The user of the device herewith confirms to the managing operator (owner) that he has received sufficient instructions about the operation and maintenance of the system. The user has received the manual, has read and taken note of its contents and consequently has all the information required for safe operation and is sufficiently familiar with the device.

The managing operator should for legal protection have the user confirm the instruction about the operation of the device.

I have read and taken note of the contents of all chapters in this manual as well as all safety instructions and warnings.

**User**

-----  
Surname, first name (block letters)

-----  
Position in the company

-----  
Place, date and signature

**Managing operator or service technician**

-----  
Surname, first name (block letters)

-----  
Position in the company

-----  
Place, date and signature



### 3 Technical Data

#### 3.1 Protective Equipment

- This device is equipped with an automatic hood lock. The locking mechanism prevents the device from being started when in an unsafe state.
- The device can only be started when the hood is closed.
- It is only possible to open the hood when the device has come to a halt.
- In the event of a failure, there is an additional electric emergency brake, which brings the knife insert to a halt in a fraction of a second also from top speed.

#### 3.2 Degree of Protection

- IP42 (IP20 in the area of the ventilation slots)

#### 3.3 Emissions

**⚠ CAUTION**

C.0020

**Risk of injury caused by not hearing acoustic signals**

Loud grinding noise

- Loud grinding noise may result in not hearing acoustic warning signals, leading to injuries.
- **Take the volume of grinding noise into consideration when designing the acoustic signals in the working environment.**
- **Where necessary, use additional visual signals.**

**⚠ CAUTION**

C4.0045

**Risk of hearing loss**

High sound level

- A high sound level may arise depending on the type of material, the type of blade insert used, the set speed and the duration of grinding. Excessive noise in terms of intensity and duration can cause impairments or lasting damage to hearing.
- **Ensure you take suitable noise protection measures.**
- **Wear hearing protection when there is loud or persistent noise.**



**Sound parameters:**

The sound parameters are also influenced by the properties of the sample material.

Example 1:

Container:	Glass container with gravity lid
Grinding body:	Knife of stainless steel
Feed material:	Tomatoes quartered (~ 40 x 25 mm)
Feed quantity:	100 g
Speed:	10 000 rpm

At these operating conditions, the workplace related equivalent continuous sound level  $L_{eq} = 66.9 \text{ dB(A)}$ .

Example 2:

Container:	Glass container with gravity lid
Grinding body:	Knife of stainless steel
Feed material:	Cheese (~ 20 x 20 mm)
Feed quantity:	100 g
Speed:	10 000 rpm

At these operating conditions, the workplace related equivalent continuous sound level  $L_{eq} = 73.9 \text{ dB(A)}$ .

### 3.4 Electromagnetic Compatibility (EMC)

- EMC class according to DIN EN 55011: A

### 3.5 Rated Power

~ 1 000 W (VA)

### 3.6 Motor Rotation Speed

The motor rated speed depends on the type of grinding:

- Cutting: 2 000 – 10 000 rpm (in steps of 500 rpm)
- Cutting with Boost function: 14 000 rpm
- Hit and impact grinding: 2 000 – 4 000 rpm (in steps of 500 rpm)

### 3.7 Dimensions and Weight

- Height: 392 mm
- Width: 350 mm
- Depth: 275 mm
- Weight: ~ 10 kg (without grinding container, without knife insert)

### 3.8 Required Floor Space

 **CAUTION**

C5.0047

**Risk of injury caused by the device falling down**

Incorrect installation of the device

- Due to its weight, the device can cause injuries if it falls down.
  - **Only operate the device on a sufficiently large, strong and stable workstation.**
  - **Ensure that all of the device feet are securely supported.**
- Height with open hood: ~ 540 mm
- Depth with open hood: ~ 450 mm
- Width of the base: 350 mm
- Depth of the base: 450 mm

No safety distances required.

**Location requirements:**

The device must be placed on a vibration-free and stable surface.

### 3.9 Receptacle Volume

The receptacle volume (feed volume) depends on the sample material and on the device configuration and setting.

- Feed volume: max. 700 ml

### 3.10 Feed Grain Size

The feed grain size depends on the sample material and on the device configuration and setting.

- Feed grain size:  $\leq 40$  mm



## 4 Packaging, Transport and Installation

### **WARNING**

W2.0000

#### **Risk of cuts**

Falling machine or parts of the machine

- The machine may fall down while it is being unpacked, and the blade insert can lead to cuts.
- **Remove the machine carefully from the packaging.**
- **Place the machine on a firm stand.**

### 4.1 Packaging

The packaging has been adapted to the mode of transport. It complies with the generally applicable packaging guidelines.

#### **NOTICE**

N3.0001

#### **Complaint or return**

Keeping the packaging

- Inadequate packaging and insufficient securing of the device can jeopardise the warranty claim in the event of a complaint or return.
- **Keep the packaging for the duration of the warranty period.**

### 4.2 Transport

#### **NOTICE**

N4.0017

#### **Damage to components**

Transport

- Mechanical or electronic components may be damaged during transport. The device must not be knocked, shaken or thrown during transport.
- **Move the device gently during transport.**

#### **NOTICE**

N5.0014

#### **Complaints**

Incomplete delivery or transport damage

- The forwarding agent and Retsch GmbH must be notified immediately in the event of transport damage. It is otherwise possible that subsequent complaints will not be recognised.
- **Please check the delivery on receipt of the device for its completeness and intactness.**
- **Notify your forwarding agent and Retsch GmbH within 24 hours.**

### 4.3 Temperature Fluctuations and Condensation

**NOTICE**

N6.0016

**Damaged components due to condensation**

Temperature fluctuations

- The device may be exposed to substantial fluctuations in temperature during transport. The ensuing condensation can damage electronic components.
- **Wait until the device has acclimatised before putting it into service.**

**Temporary storage:**

Also in case of an interim storage the device must be stored dry and within the specified ambient temperature range.

### 4.4 Conditions for the Installation Site

- Installation height: max. 2 000 m above sea level
- Ambient temperature: 5 °C – 40 °C

**NOTICE**

N7.0021

**Ambient temperature**

Temperatures outside the permitted range

- Electronic and mechanical components may be damaged.
- The performance data alter to an unknown extent.
- **Do not exceed or fall below the permitted temperature range (5 °C to 40 °C ambient temperature) of the device.**
- Maximum relative humidity < 80 % (at ambient temperatures ≤ 31 °C)

For ambient temperatures  $U_T$  between 31 °C and 40 °C, the maximum relative humidity value  $L_F$  linearly decreases according to  $L_F = -(U_T - 55) / 0.3$ :

Ambient temperature	Max. rel. humidity
≤ 31 °C	80 %
33 °C	73.3 %
35 °C	66.7 %
37 °C	60 %
39 °C	53.3 %
40 °C	50 %

**NOTICE**

N8.0015

**Humidity**

High relative humidity

- Electronic and mechanical components may be damaged.
- The performance data alter to an unknown extent.
- **The relative humidity in the vicinity of the device should be kept as low as possible.**

## 4.5 Electrical Connection

**WARNING**

W3.0015

**Risk to life caused by an electric shock**  
 Connection to socket without a protective earth conductor

- Connecting the device to sockets without a protective earth conductor can lead to life-threatening injuries caused by an electric shock.
- **Always operate the device using sockets with a protective earth conductor (PE).**

NOTICE

**NOTICE**

N9.0022

**Electrical connection**  
 Failure to observe the values on the type plate

- Electronic and mechanical components may be damaged.
- **Connect the device only to a mains supply matching the values on the type plate.**

- WARNING** When connecting the power cable to the mains supply, use an external fuse that complies with the regulations applicable to the place of installation.
- Check the type plate for details on the necessary voltage, frequency, and maximum external current source fuse for the device.
  - The listed values must agree with the existing mains supply.
  - Only use the supplied power cable to connect the device to the mains supply.

**NOTICE** The external fuse must amount 16 A (delay-action).

## 4.6 Type Plate Description

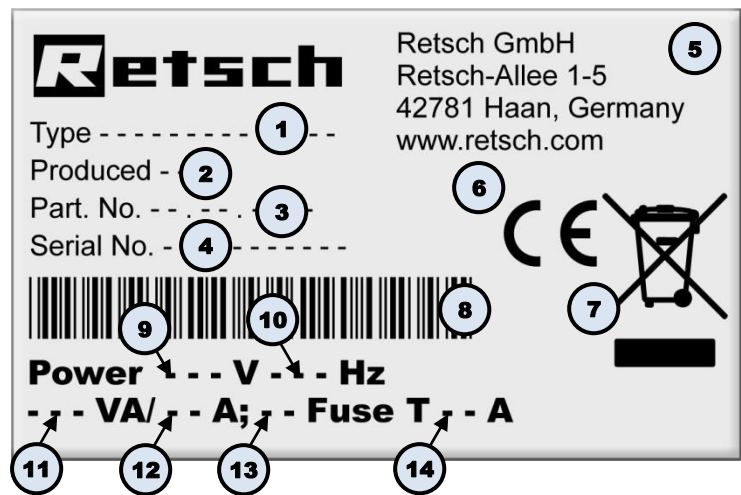

Fig. 1: Type plate

- 1 Device designation
- 2 Year of production
- 3 Part number
- 4 Serial number
- 5 Manufacturer's address
- 6 CE marking
- 7 Disposal label

- 8 Bar code
- 9 Power version
- 10 Mains frequency
- 11 Capacity
- 12 Amperage
- 13 Number of fuses
- 14 Fuse type and fuse strength

① In the case of queries please provide the device designation **(1)** or part number **(3)**, as well as the serial number **(4)** of the device.

## 5 First Commissioning

**⚠ WARNING** W4.0002

**Danger to life through electric shock**  
Damaged power cable

- Operating the device with a damaged power cable or plug can lead to life-threatening injuries caused by an electric shock.
- **Before operating the device, check the power cable and plug for damage.**
- **Never operate the device with damaged power cable or plug!**



**NOTICE** N10.0002

**Setting up the device**  
Disconnecting the device from the mains

- A separation of the device from the mains must be possible at any time.
- **Set up the device in such a way, that the connection for the power cable is always easily accessible.**

**NOTICE** N11.0004

**Setting up the device**  
Vibrations during operation

- Depending on the operating mode of the device, slight vibrations may occur.
- **Set up the device only on a vibration-free, plane and stable surface.**

No further precautions need to be taken for the first commissioning. The device can be put into operation immediately after installation.

## 6 Operating the Device

**⚠ CAUTION**

C6.0005

**Risk of injury**

Potentially explosive atmosphere

- The device is not suitable for use in potentially explosive atmospheres. Operating the device in a potentially explosive atmosphere can lead to injuries caused by an explosion or fire.
- **Never operate the device in a potentially explosive atmosphere!**

**⚠ CAUTION**

C7.0006

**Risk of injury**

Sample material that is harmful to health

- Sample material that is harmful to health can injure people (illness, contamination).
- **Use suitable extraction systems with sample material that is harmful to health.**
- **Use suitable personal protective equipment with sample material that is harmful to health.**
- **Take note of the safety data sheets for the sample material.**



**⚠ CAUTION**

C8.0004

**Risk of injury**

Explosive or flammable samples

- Samples can explode or catch fire during the grinding process.
- **Do not use any samples in this device that carry a risk of explosion or fire.**
- **Take note of the safety data sheets for the sample material.**



**⚠ CAUTION**

C9.0010

**Risk of burns or poisoning**

Varying sample properties

- The properties and therefore also the chemical reactivity of the sample can change during the grinding process and can cause burns or poisoning as a result.
- **Do not process any substances in this device whose chemical reactivity is so changed by grinding that there is a risk of explosion or poisoning.**
- **Take note of the safety data sheets for the sample material.**



**⚠ CAUTION** Please consult the manufacturer before using organic solvents!

**NOTICE**

N12.0007

**Handling foodstuffs, pharmaceuticals and cosmetic products**

Products processed

- Foodstuffs, pharmaceuticals and cosmetic products that have been processed on the device may no longer be eaten, used or put into circulation,.
- **Dispose of these substances according to applicable directives.**

**NOTICE**

N13.0007

**Range of application of the device**

Long-term operation

- This laboratory device is designed for eight-hour single-shift operation with a duty cycle of 30 %.
- **This device may not be used as a production machine nor is it intended for continuous operation.**

## 6.1 Principle of Operation

Two sharp, robust blades rotate in the centre of the grinding container. Depending on the direction of rotation, grinding is effected with the blunt knife side by hit and impact effect, or the sharp knife blades by cutting. A selection of various lids and grinding containers allows the device to be adapted to individual application requirements.

The preselected speed is kept constant during the grinding process by a speed control. The speed can also be reset during operation in manual mode. The grinding duration is adjustable up to three minutes. At the end of the grinding duration, the motor is automatically stopped and the hood opens.

## 6.2 Views of the device

### 6.2.1 Front



**Fig. 2:** Front view of the device

Element	Description	Function
<b>A</b>	Locking mechanism	Keeps the device closed
<b>B</b>	Operating controls with rotary knob	Operation of the device
<b>C</b>	Grinding container	Container for the sample material
<b>D</b>	Lid of the grinding container	Closes the grinding container
<b>E</b>	Knife insert	Grinds the sample material
<b>F</b>	Hood	Closes the device



6.2.2 Back

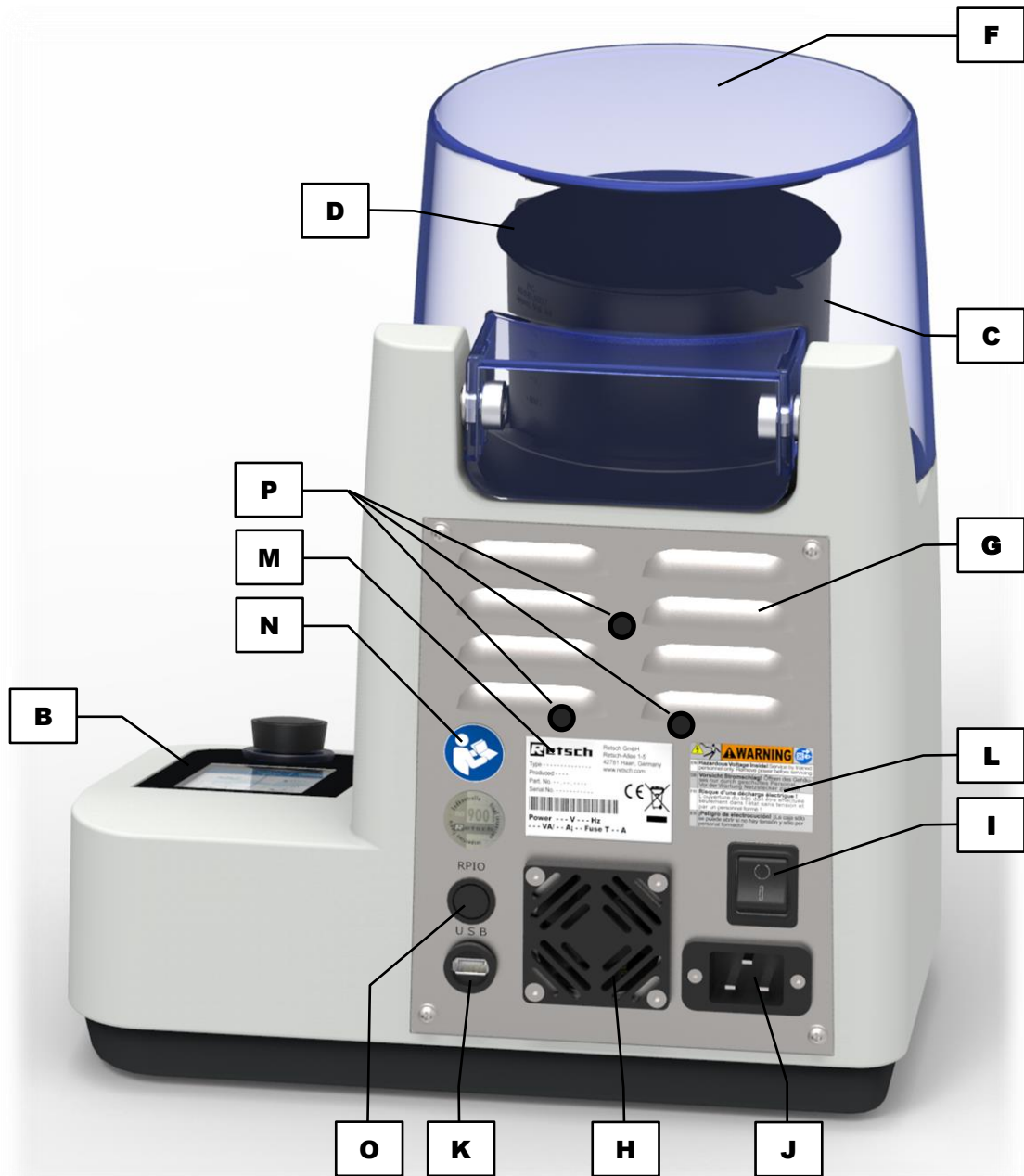

Fig. 1: Rear view of the machine

Element	Description	Function
<b>B</b>	Control element with knob	For operating the machine
<b>C</b>	Grinding jar	Container for the sample material
<b>D</b>	Lid on the grinding jar	Seals the grinding jar
<b>F</b>	Hood	Closes the machine
<b>G</b>	Air vents	For exhaust air from the motor and inside of the machine
<b>H</b>	Housing fan	Fan for waste heat

Element	Description	Function
<b>I</b>	On/off switch	Switches the machine on and off, disconnects the machine from the mains
<b>J</b>	Mains connection	Connection for the power cable
<b>K</b>	USB interface	Data connection
<b>L</b>	Warning sign "Pull out the plug "	Warns about the risk of an electric shock
<b>M</b>	Type plate	Lists the voltage version, serial number and model among other things
<b>N</b>	"Manual" sticker	Draws attention to reading the manual
<b>O</b>	Interface for the Wi-Fi connection (RPIO)	Data connection for connecting Wi-Fi to the Retschbox (optional accessory)
<b>P</b>	Rubber coupling for the Retschbox	For securing the Retschbox

### 6.3 Switching On / Off

⇒ Turn on the GM 200 with the mains switch (**I**) on the back side of the device.

When the device is switched off, it is completely disconnected from the mains.

### 6.4 Opening and Closing of the Device

#### 6.4.1 Opening

- ⇒ Connect the device to the mains.
- ⇒ Switch the device on by means of the mains switch (**I**).
- ⇒ Press the  button (**B3.1**). The locking mechanism is released and the hood opens.

#### 6.4.2 Closing

**⚠ CAUTION**

C10.0008

**Risk of pinching and bruising**

Device hood closing

- The device hood can trap fingers when closing, thereby causing pinching or bruising.
- **Never allow the device hood to close by itself.**
- **Always hold the device hood firmly when closing it.**



⇒ Press the hood (**F**) downwards. The locking mechanism (**A**) locks automatically.

## 6.5 Inserting the Grinding Container

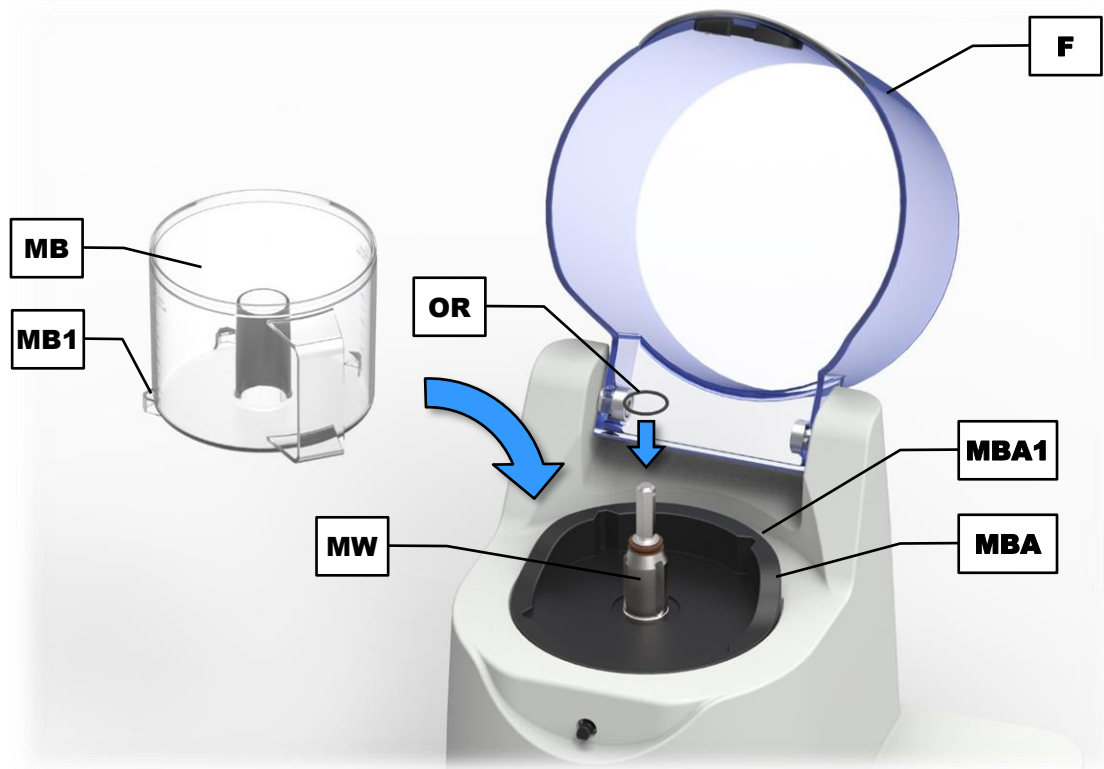

**Fig. 3:** Inserting the grinding container

- ⇒ Open the hood (**F**).
- ⇒ Insert the grinding container (**MB**).

**NOTICE** Depending on the design, the grinding container has one to three anti-rotation locks (**MB1**) which fit into the grooves (**MBA1**) of the grinding container receptacle (**MBA**). On insertion, pay attention to the correct orientation of the grinding container.

**NOTICE** An O-ring (**OR**) serves as a seal and fixation for the grinding container receptacle (**MBA**). When inserting the grinding container, ensure the correct seating of the O-ring in the groove of the motor shaft (**MW**).

Grinding containers made of different materials are available for the GM 200 from Retsch GmbH. **NOTICE** Not all grinding containers are suitable for the grinding of all sample materials! Please note the following table when selecting the grinding container:

Type of grinding container	Suitable for	Unsuitable for
Plastic container	soft, medium hard, elastic, aqueous, greasy and oily sample material	hard, hard-brittle sample material due to increased abrasion
Glass container	soft, medium hard, elastic, aqueous, greasy and oily sample material	hard, hard-brittle sample material due to risk of fracture
Stainless steel container	soft, medium hard, elastic, aqueous, greasy, oily, hard and hard-brittle sample material	–

## 6.6 Inserting the Knife Insert

**⚠ CAUTION**

C11.0028

**Risk of cuts**

Improper handling of the blade insert

- The blades on the blade insert are extremely sharp and may cause cuts if not handled properly.
- **Always wear suitable protective gloves when touching the blades in the blade insert.**

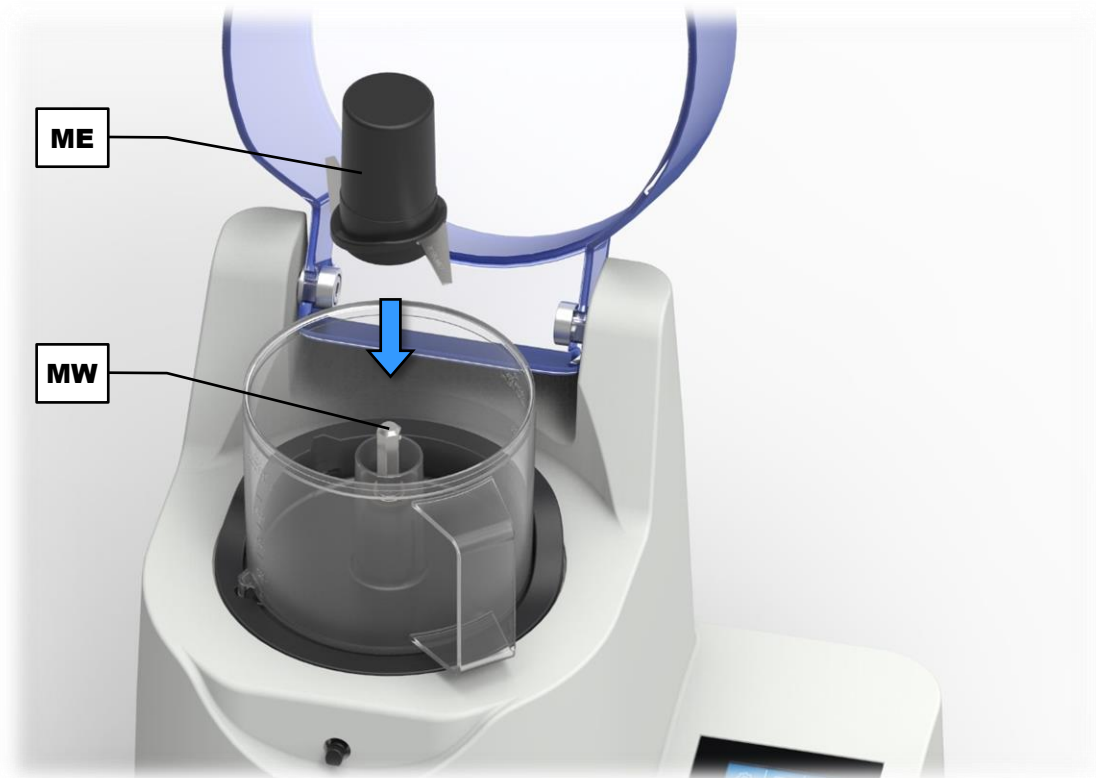

**Fig. 4:** Inserting the knife insert

⇒ Put the knife insert (**ME**) onto the motor shaft (**MW**) and slide it downwards up to the stop.

## 6.7 Filling the Grinding Container

### CAUTION

C12.0039

#### Risk of cuts

##### Sharp blade insert

- The blades in the blade insert are extremely sharp and may cause cuts if not handled properly.
- **Wear protective gloves when handling the blades in the blade insert.**
- **Do not touch the blades in the blade insert.**
- **Remove the grinding jar from the machine before reaching into the grinding jar.**
- **Do not reach into the grinding jar while sample material is covering the blade insert.**
- **Before taking the blade insert out, remove as much sample material from the grinding jar as necessary to enable you to safely grasp the blade insert.**



### NOTICE

N14.0054

#### Filling the grinding container

##### Inserting the knife insert

- Insert the knife insert before the sample material is fed, otherwise the sample material can be jammed between the knife insert and the grinding container.
- **Fill the grinding container only with the knife insert inserted.**

### 6.7.1 Filling within the Device

- ⇒ Open the hood (F).
- ⇒ Insert the grinding container (MB) and the knife insert (ME).
- ⇒ Place the sample in the grinding container.
- ⇒ Fit the lid.
- ⇒ Close the hood (F).

### 6.7.2 Filling outside the Device

The grinding container can also be filled before it is inserted into the device. Hence, it is possible to work with several grinding containers without intermediate cleaning.

**NOTICE** The loading of the grinding container outside of the device can only be carried out with the reduction lid and the standard lid. The gravity lid is not suitable for this!

- ⇒ Insert the knife insert (ME) into the grinding container (MB).
- ⇒ Place the sample in the grinding container.
- ⇒ Fit the lid.
- ⇒ When inserting the grinding container (MB) press the lid downwards **in its centre**.

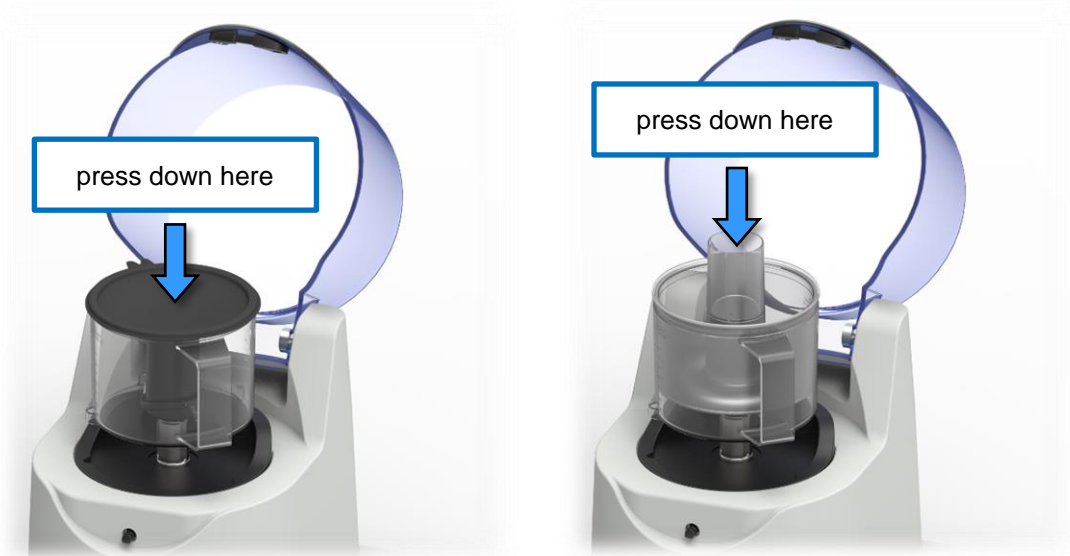
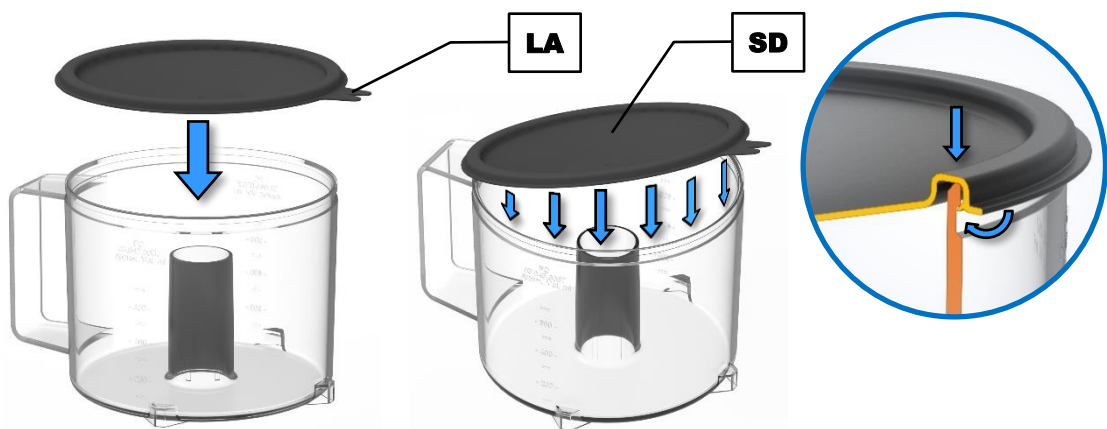

**Fig. 5:** Inserting the filled grinding container with the standard lid (left) and the reduction lid (right)

**NOTICE** With the reduction lid, the pressing down is absolutely necessary to have the knife insert reaching its end position and locking into place. Do not use the gravity lid when filling the grinding container outside the device, since the knife insert in combination with the gravity lid will not lock during insertion!

⇒ Close the hood (F).

## 6.8 Closing the Grinding Container



**Fig. 6:** Closing the grinding container with the standard lid

The standard lid (**SD**) fits all available grinding containers. The standard lid is clamped on the edge of the container and can be released again with the lug (**LA**).

⇒ Press the standard lid (**SD**) from the top diagonally across the opening of the grinding container (**MB**).

⇒ Check the tight clamping of the standard lid on the grinding container.

For the GM 200 various lids are available from the Retsch GmbH. The different lid-grinding container combinations allow for an optimum adjustment to the individual tasks.

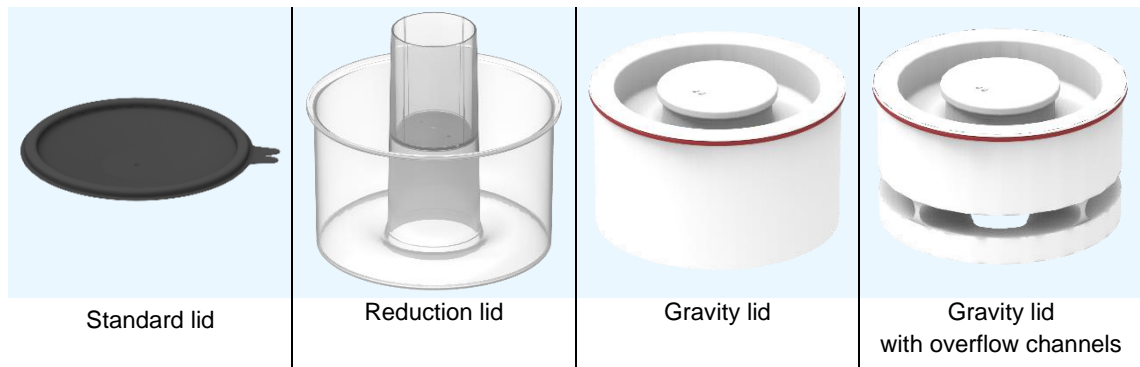

Fig. 7: Lids for the GM 200

**NOTICE** The feed volume depends on the properties of the sample material or the lid used. Do not exceed the recommended feed volume listed in the following table!

Type of lid	Application and feed volume
Standard lid	<ul style="list-style-type: none"> <li>– for larger quantities of small-sized materials</li> <li>– feed volume: 300 ml to max. 700 ml</li> <li>– suitable for all grinding containers</li> </ul>
Reduction lid	<ul style="list-style-type: none"> <li>– for smaller quantities of small-sized materials</li> <li>– feed volume: max. 300 ml (grinding chamber reduction to 0.5 l) max. 200 ml (grinding chamber reduction to 0.3 l)</li> <li>– only for the plastic container</li> </ul>
Gravity lid	<ul style="list-style-type: none"> <li>– for smaller quantities of dry materials</li> <li>– feed volume: max. 300 ml</li> <li>– available in two versions: for the plastic container for the glass or stainless steel container</li> </ul>
Gravity lid with overflow channels	<ul style="list-style-type: none"> <li>– for smaller quantities of aqueous materials</li> <li>– feed volume: max. 300 ml</li> <li>– available in two versions: for the plastic container for the glass or stainless steel container</li> </ul>

The reduction lid is held down by the hood (F) during the grinding process.

The gravity lid allows for an exact adjustment of the usable volume to the respective feed volume. It moves downwards during the grinding and optimises the grinding chamber volume.

**NOTICE**

N15.0053

**Cryogenic grinding**

Grinding with liquid nitrogen (LN<sub>2</sub>)

- When grinding with liquid nitrogen, breakage of the grinding set and damage to the device can occur!
- **Grinding with liquid nitrogen is not permitted!**

## 6.9 Full-Metal Knife

**NOTICE** Only use a stainless steel grinding jar and an full-metal stainless steel cutter as cooling components for embrittling the sample material when grinding using dry ice! The plastic components on the standard blade insert and the plastic grinding jars may become brittle and break under these conditions.



**Fig. 2:** Stainless steel grinding jar with lid

**NOTICE** Always fill the grinding jar outside of the machine when grinding using dry ice. Do not leave the grinding jar in the machine; remove it again directly on completing the grinding process so as to avoid damage to the equipment.



**Fig. 3:** Correct filling when grinding using dry ice and sample

**⚠ WARNING**

W5.0000

**Cryogenic grinding**

Grinding with liquid nitrogen (LN<sub>2</sub>)

- When grinding with liquid nitrogen, breakage of the grinding set and damage to the device can occur!
- **Grinding with liquid nitrogen is not permitted!**



**⚠ CAUTION**

C13.0000

**Risk of injury due to frozen CO<sub>2</sub> (dry ice)**

Use of dry ice during cryogenic grinding

- Dry ice has a temperature of  $-78\text{ °C}$  and causes injuries similar to burns or frostbite if it comes into contact with skin and eyes.
- **Follow the safety data sheets.**
- **Always wear protective goggles and gloves when using dry ice.**



**6.9.1 Blade Protection**

**⚠ CAUTION**

C14.0001

**Risk of cuts**

Sharp full-metal cutter

- The blades on the full-metal cutter are extremely sharp and can result in cuts if not used correctly.
- **Only hold the full-metal cutter on the edge of the grip of the cutting cylinder.**
- **Never touch the blades of the full-metal cutter without suitable protective gloves.**

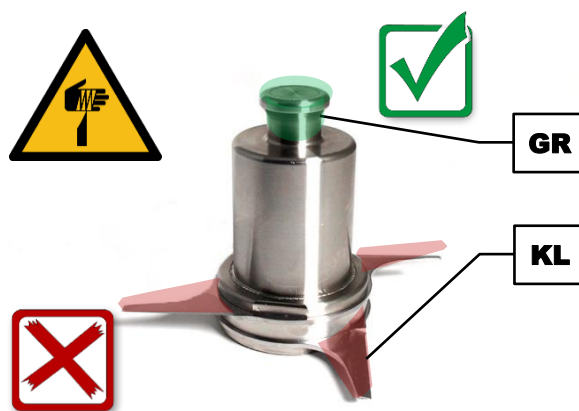

**Fig. 4:** Handling the full-meter cutter

- ⇒ Always hold the full-metal cutter by the edge of the grip (**GR**) of the cutting cylinder.
- ⇒ Do **not** touch the full-metal cutter by the blades (**KL**)!

The full-metal cutter is supplied with a blade protector (**KS**).



**Fig. 5:** Full-metal cutter with blade protector

The full-metal cutter should always be stored with the blade protector applied.

### 6.9.2 Cleaning the Full-Metal Knife

The cleaning of the full-metal knife should be carried out after each use.

All parts can be cleaned with alcohol, petrol or normal household detergent and water.

The knife is dishwasher safe and autoclavable.

#### **⚠ CAUTION**

C15.0001

##### **Lid becoming pressed on when grinding using dry ice**

Volume of the resulting gas

- Bear in mind the amount of dry ice used and the associated volume of the resulting gas when grinding using dry ice (CO<sub>2</sub>).
- The grinding jar lids specifically suitable for cryogenic grinding have different ventilation properties and may be pressed on by the large volume of the resulting gas.
- Do **not** use the standard lid!

## 7 Grinding by means of cold grinding

Sample material that can only be ground with difficulty or not at all at normal room temperatures (gummi bears, vegetables without added water, creamy cakes) must be cold ground.

Embrittlement with dry ice (frozen CO<sub>2</sub>) improves the fracture behaviour of such samples. The sample is mixed with dry ice at a ratio of 1:2 (E:R), allowed to cool for a few minutes then added to the grinding jar. Here the grinding jar should only be filled to 30% or to a maximum of 50%.

### 7.1 Minimising wear to the blade and achieving good homogenisation results

In the case of cold grinding, the sample should first be pre-crushed in reverse mode at a maximum 4000 rpm-1. The sample material is frozen solid and is pre-crushed in reverse mode using the blunt side of the rotating blade. This protects the sharp side of the blade which can

then be used in forward operation in a second grinding process to homogenise the sample to the desired degree of fineness.

At the start of grinding the hard pieces of sample should be no bigger than 1 – 2 cm in order to maximise the service life of the blades.

With hard samples it is generally advantageous to carry out pre-crushing at a lower speed.

## 7.2 Risk of injury to eyes and skin due to severe frostbite

### CAUTION

#### Risk of injury due to frozen CO<sub>2</sub> (dry ice)

Use of dry ice during cryogenic grinding

- Dry ice has a temperature of  $-78\text{ °C}$  and causes injuries similar to burns or frostbite if it comes into contact with skin and eyes.
- **Follow the safety data sheets.**
- **Always wear protective goggles and gloves when using dry ice.**

C16.0000



### CAUTION

#### Risk of injury to eyes and skin

Ejected particles

- Particles may be ejected from the grinding jar when grinding sample material.
- **Always wear protective goggles when using the machine.**
- **Follow the safety data sheets for the sample material.**

C17.0031



**WARNING** During grinding the dry ice is heated and the frozen CO<sub>2</sub> sublimed. The gas takes up more space, therefore it is essential to use the special lid for cryogenic grinding. This enables the gas to evaporate, thereby avoiding excess pressure.



Fig. 6: Special lid for cryogenic grinding in the GM200

## 7.3 Corrugated grinding jars for improved mixing of the sample

The full-metal cutter on the GM 200 has four blades, and this can result in the sample gliding along the side of the container during grinding. The corrugated stainless steel grinding jar interrupts the gliding, thereby ensuring better mixing and substantially better grinding results compared to the non-corrugated stainless steel container.



## 8 Controlling the Device

### 8.1 Operating Controls, Displays and Functions

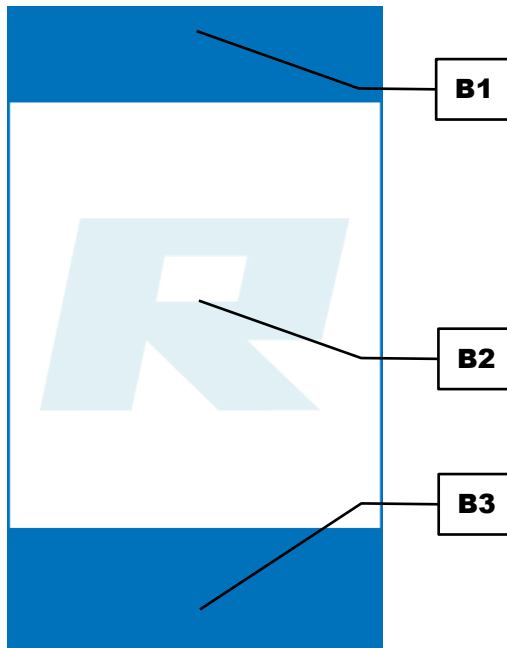

Fig. 8: Control panel areas

Element	Description	Function
<b>B1</b>	Navigation	Selection of the operating modes "Manual", "Programme" and "Sequence". Access to the menu "Settings"
<b>B2</b>	Settings and display of parameters	Settings of grinding parameters and display of parameters during the grinding process
<b>B3</b>	Device control	Start, stop, open hood

**NOTICE** Only those functions (icons) are displayed which are also possible for the current operation.

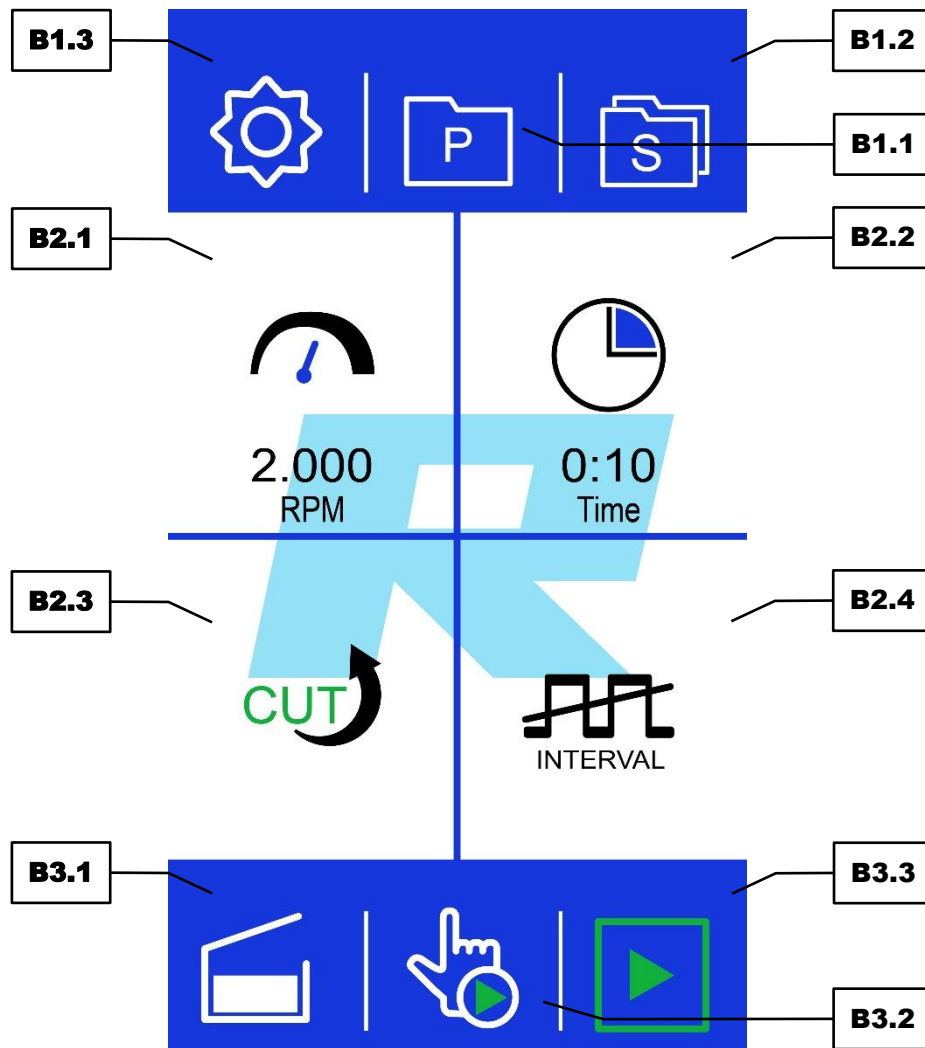

Fig. 9: Control elements and functions



Element	Description	Function
<b>B1.1</b>	Programme settings	Access to the programme settings
<b>B1.2</b>	Sequence settings	Access to the sequence settings
<b>B1.3</b>	Settings	Access to the settings
<b>B2.1</b>	Speed	Displays the set speed
<b>B2.2</b>	Process time	Displays the grinding duration
<b>B2.3</b>	Direction of rotation	Displays the set direction of rotation
<b>B2.4</b>	Interval	Indicates whether the interval grinding is active or inactive
<b>B3.1</b>	Open	Opens the locking mechanism of the hood
<b>B3.2</b>	Quick Start	Performs the grinding process, as long as the button is pressed
<b>B3.3</b>	Start, Stop	Starts or stops the grinding process

## 8.2 Operating Modes and Navigation

The device can be operated entirely using the touchscreen. The operating software can be divided into three operating modes:

- Manual
- Programme
- Sequence

### 8.2.1 Navigation between Operating Modes

- ⇒ Enter the desired grinding parameters in the control panel area of the settings (**B2**) to perform a manual grinding.
- ⇒ Press the  button (**B1.1**) to enter the programme settings.
- ⇒ Press the  button (**B1.2**) to enter the sequence settings.

## 8.3 Grinding Parameters

The grinding parameters can be set or changed via the control panel. It can be distinguished between adjustable parameters and parameters that can be activated or deactivated.

### 8.3.1 Adjustable Parameters

The following parameters can be set via data entry:

- Process time
- Speed

In manual mode the parameters can be edited directly. In programme mode the parameters can only be changed, when the edit mode has been activated via the  button (**B3.4**).

- ⇒ Press on the parameter to be edited. The background is highlighted in grey and the border of the rotary knob (**B4**) lights up blue.
- ⇒ Turn the rotary knob until the desired value is displayed.

The set value is applied as soon as the parameter is pressed again, or another parameter is selected.



**Fig. 10:** Rotary knob





**Process time (B2.2):**

The process time indicates the total duration of the grinding process. Via the rotary knob, a process time between 0:01 and 3:00 (m:ss) can be set. The process time between 0:01 and 0:30 can be set in steps of 1 second, the process time between 0:30 and 3:00 in steps of 5 seconds. After the grinding process is started, the process time continuously counts down to 0:00. When the interval function is activated, the process time includes both, the interval times and the pause times.

**Speed (B2.1):**

The speed (revolutions per minute, rpm) can be set via the rotary knob. The speed range depends on the direction of rotation:

Icon	Direction of rotation	Speed range
	Counterclockwise (cutting)	2 000 – 10 000 rpm, adjustable in steps of 500 rpm
	Clockwise (hit and impact grinding)	2 000 – 4 000 rpm, adjustable in steps of 500 rpm

A short-time increase in speed to approx. 14 000 rpm can be achieved with the boost function during the grinding by cutting.

**8.3.2 Activatable or Deactivatable Parameters**

The following parameters can be activated or deactivated:

- Interval
- Direction of rotation

In manual mode the parameters can be edited directly. In programme mode the parameters can only be changed, when the edit mode has been activated via the  button (B3.4).

⇒ Press on the parameter to be edited. The direction of rotation is changed, or the interval grinding is activated or deactivated.

**Speed (B2.3):**

Depending on the direction of rotation of the knife insert, the sample is ground either by cutting or by hit and impact effect. The current direction of rotation of the knife insert is displayed by one of the following icons:



Direction of rotation counterclockwise (cutting)



Direction of rotation clockwise (hit and impact grinding)

**NOTICE** Hard and hard-brittle sample materials should be ground mainly with hit and impact grinding, i.e. with direction of rotation .

**Interval (B2.4):**

By activating the interval function, the grinding is interrupted and continued again at short, constant intervals. The activated or deactivated interval function is displayed by one of the following icons:



Interval grinding activated



Interval grinding deactivated (permanent grinding)

**NOTICE** With the interval function activated, the maximum speed is limited to 4 000 rpm, regardless of the direction of rotation.

## 8.4 Manual Mode



In manual mode, the following grinding parameters can be edited directly:

- Speed
- Process time
- Direction of rotation
- Interval

A detailed description of the parameter settings can be found in Chapter "[Grinding Parameters](#)".

### Quick Start (B3.2):

Depending on the sample material, different grinding parameters are necessary in order to achieve the optimum grinding. By means of the Quick Start function, the set speed can be tested on the sample and adjusted if necessary.





- ⇒ Press the  button (B3.2). The button changes to  and the grinding process starts immediately with the set speed. The grinding process stops automatically after five seconds.
- ⇒ Press the  button to terminate the Quick Start grinding prematurely.

### 8.4.1 Start Process

① After switching on the device, the  button (B3.3) is hidden, until the hood is once opened and closed again.

- ⇒ Press the  button (B3.3) to start the grinding process.

In the control panel area of the navigation (B1), all buttons are hidden. Depending on the direction of rotation, different buttons appear in the control panel area of the device control (B3):

- If the sample is ground by hit and impact effect (the  icon is displayed as direction of rotation), only the  button appears.
- If the grinding process is performed by cutting (the  icon is displayed as direction of rotation), the  button appears in addition to the  button.

During manual grinding, the speed can be changed and/or the interval function be activated or deactivated. All other parameters cannot be changed during operation.

### Boost function:

- ⇒ Press the  button to increase the speed for a short time to approx. 14 000 rpm during the grinding by cutting.

By pressing the button, the boost function can be performed for a maximum of 3 seconds.

**NOTICE** The boost function can only be used once during one grinding process and is again

available at the next process start, only. Furthermore, the boost function must **not** be performed with an **empty grinding container!**

### 8.4.2 Stop Process

The grinding process is terminated automatically after the set process time has elapsed. However, the grinding process can be stopped manually at any time.

⇒ Press the button to stop the grinding process.

① The hood opens automatically after the set process time has elapsed, or the grinding process has been stopped manually.

## 8.5 Programme Mode

Often different but perseverative sample materials with individual grinding parameters are being processed. For such samples, individual grinding parameter sets can be saved in programmes and retrieved when needed.

There are eight programme memory positions available. The following grinding parameters can be stored in the individual programmes:

- Speed
- Process time
- Direction of rotation
- Interval

Please refer to Chapter "[Grinding Parameters](#)" for a detailed description of the parameter settings.

### 8.5.1 Select a Program

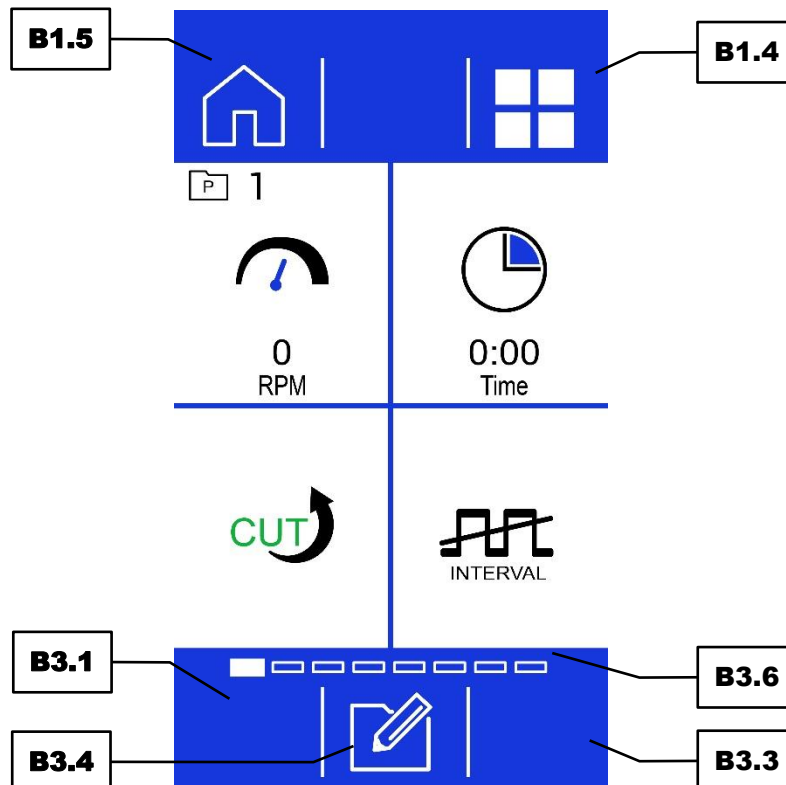



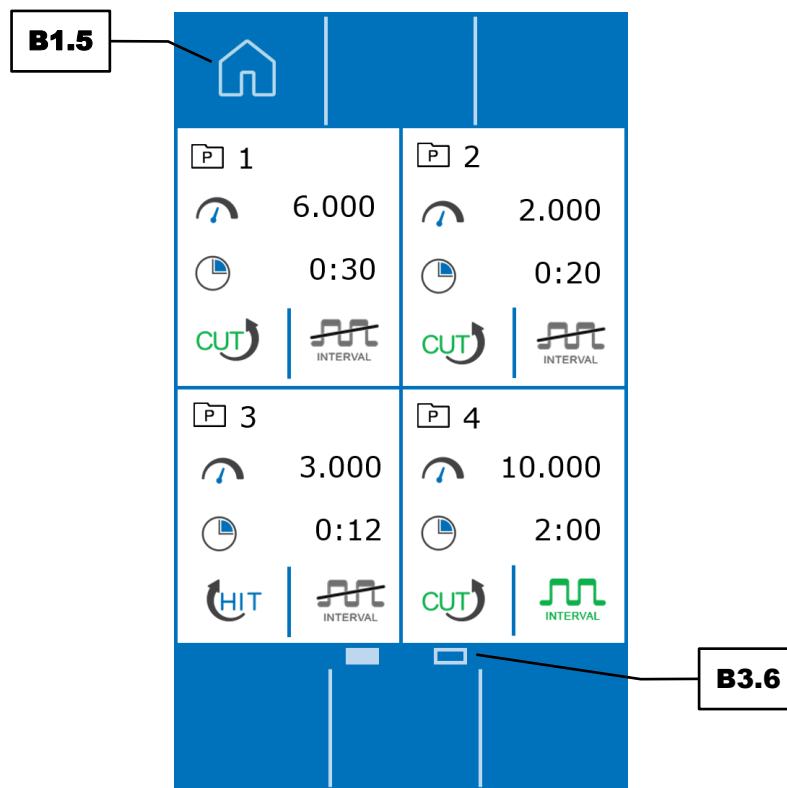

Fig. 11: Functions of the programme mode in the programme view



- ⇒ Press the  button (**B1.1**) to change to the programme mode. The display changes to the current programme. The programme number is displayed next to the  icon in the upper, left quadrant.
- ⇒ To navigate ascending or descending through the programmes, wipe from right to left or from left to right, respectively over the display in the control panel area of the settings (**B2**). The position of the programme is displayed in the scroll bar (**B3.6**).

Alternatively, the programme overview can be accessed by pressing the  button (**B1.4**). Each programme is displayed in a quadrant.

- ⇒ Wipe over the display in the control panel area of the settings (**B2**) to switch between the programme group 1 – 4 and 5 – 8.
- ⇒ To load a programme, press on the upper third of the desired quadrant.



**Fig. 12:** Functions of the programme mode in the programme overview

- ⇒ Press the  button (**B3.3**) to start the selected programme and thus the grinding process.
- ⇒ To exit the programme mode and to return to the manual mode, press the  button (**B1.5**).

### 8.5.2 Edit a Program

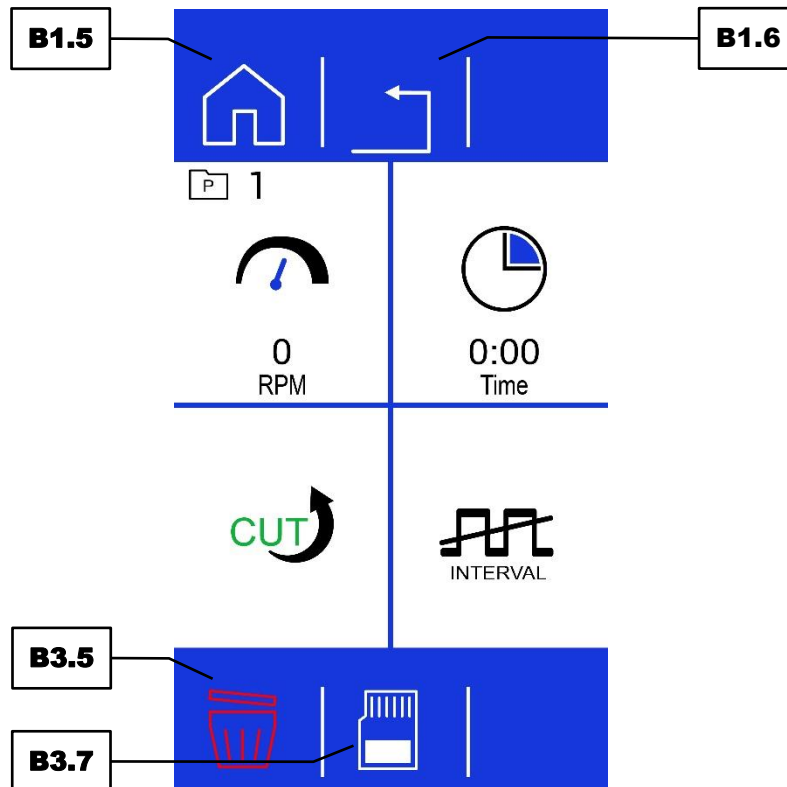





Fig. 13: Editing a programme

- ⇒ Press the  button (B3.4) to edit the programme.
- ⇒ Enter the desired grinding parameters.

The process can be cancelled by pressing the  button (B1.6). All settings are discarded.

### 8.5.3 Save a Programme

- ⇒ Press the  button (B3.7) to save the set grinding parameters in the selected programme memory position.

### 8.5.4 Delete a Programme

- ⇒ Press and hold the  button (B3.5) for approx. two seconds to delete the grinding parameters in the selected programme memory position.

After clearing the settings, the speed and the process time of this programme memory position are set to zero. The interval function is deactivated and the direction of rotation is set to cutting.

## 8.6 Sequence Mode

For special grinding tasks, grinding sequences can be set in this mode.

There are four sequence memory positions available. Each sequence consists of two consecutive, freely selectable parameter sets.

Please refer to Chapter "[Grinding Parameters](#)" for a detailed description of the parameter settings.

### 8.6.1 Select a Sequence

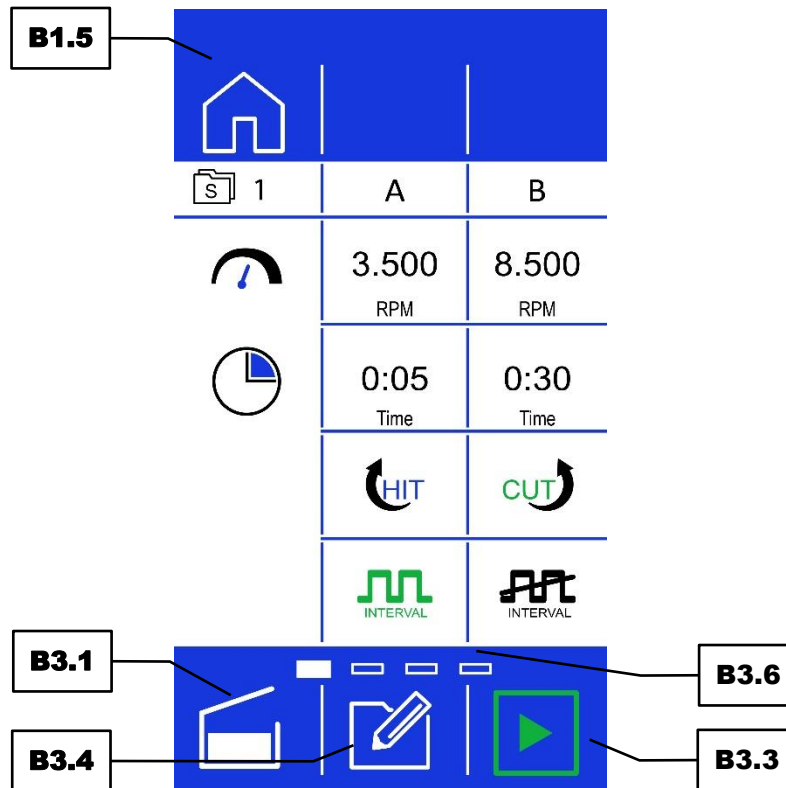



Fig. 14: Functions of the sequence mode

⇒ Press the  button (B1.2) to change to the sequence mode. The display changes to the current sequence. The sequence number is displayed next to the  icon in the upper, left corner.

⇒ To navigate ascending or descending through the sequences, wipe from right to left or from left to right, respectively over the display in the control panel area of the settings (B2). The position of the sequence is displayed in the scroll bar (B3.6).

A sequence consists of two parameter sets A and B.

⇒ Press the  button (B3.3) to start the selected sequence and thus the grinding process.

During the grinding process, the currently processed parameter set of the sequence is displayed in the navigation area (B1).

⇒ To exit the sequence mode and return to the manual mode, press the  button (B1.5).

### 8.6.2 Edit a Sequence

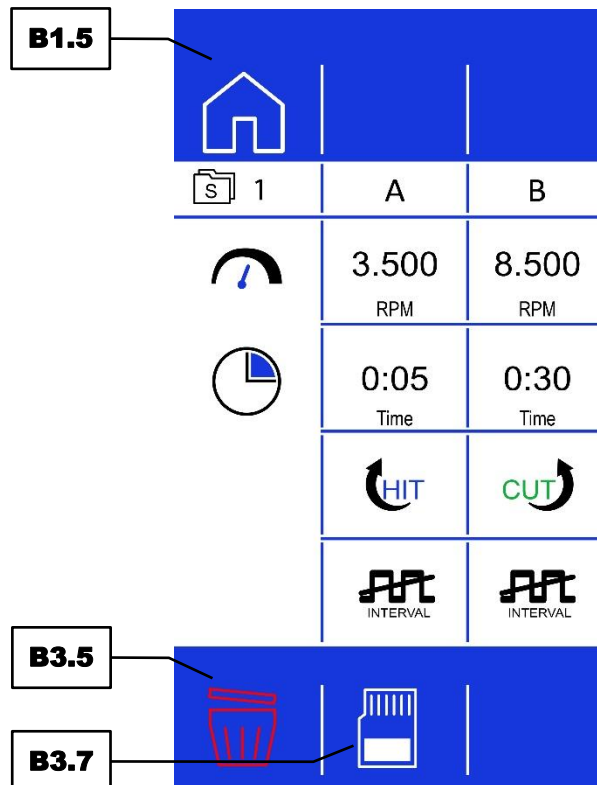





Fig. 15: Editing a sequence

- ⇒ Press the  button (B3.4) to edit the sequence.
- ⇒ Enter the desired grinding parameters for the parameter sets A and B.

The process can be cancelled by pressing the  button (B1.6). All settings are discarded.

### 8.6.3 Save a Sequence

- ⇒ Press the  button (B3.7) to save the set grinding parameters in the selected sequence memory position.

### 8.6.4 Delete a Sequence

- ⇒ Press and hold the  button (B3.5) for approx. two seconds to delete the grinding parameters in the selected sequence memory position.

After clearing the settings, the speed and the process time of the two parameter sets A and B are set to zero. The interval function is deactivated and the direction of rotation is set to cutting.

## 8.7 Settings

The settings of the GM 200 can only be accessed from the manual mode.

- ⇒ Press the  button (B1.3).



Abb. 7: Settings



Abb. 8: Settings



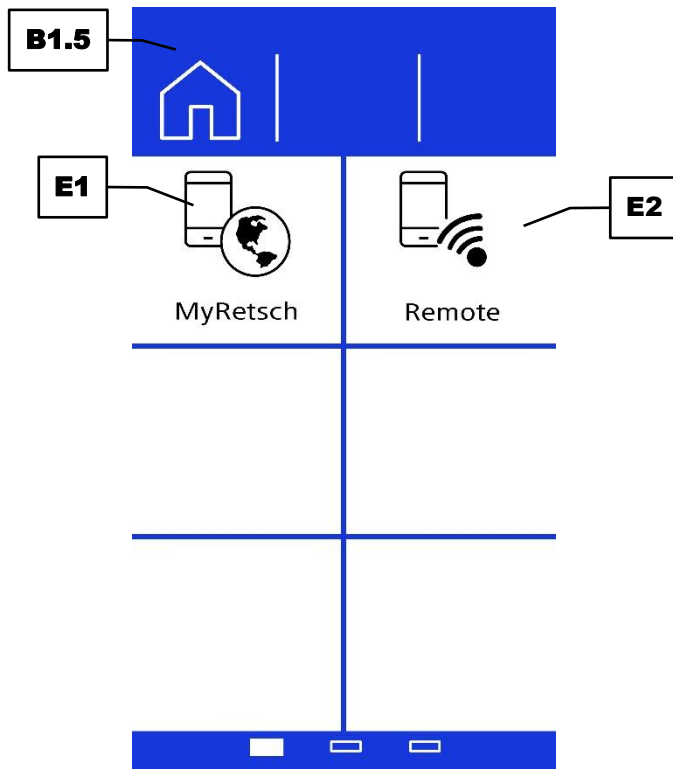

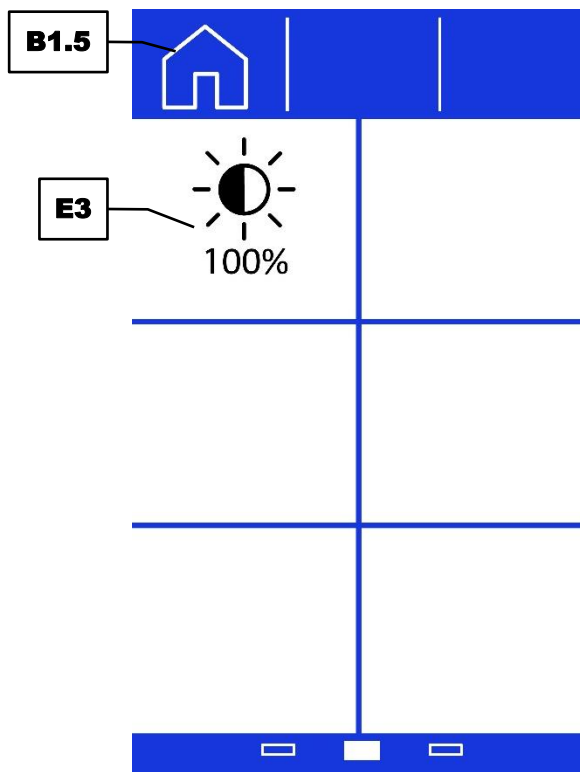

Abb. 9: Settings

The following functions and information can be accessed in the settings:

- Software versions (information)
- Operating hours (information)
- Display brightness (adjustable)
- Web portal
- Service environment
- Software update

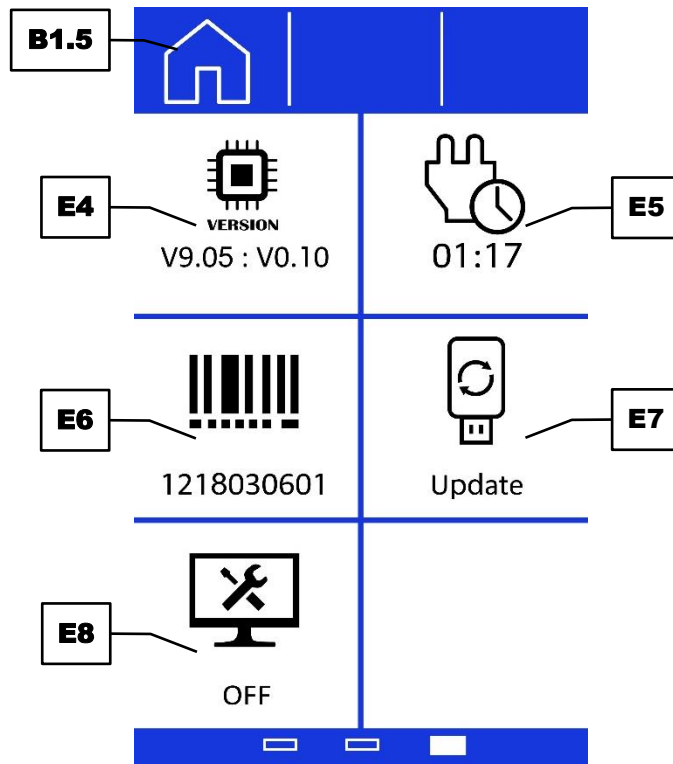
The individual functions and information are described in detail in the following subchapters.

⇒ To exit the settings and return to the manual mode, press the  button (**B1.5**).

### 8.7.1 myRetsch

Section (**E1**) permits access to the myRetsch portal of Retsch GmbH by means of a QR code. This can be scanned in using a mobile phone with the corresponding software and an internet connection. It is then possible to obtain direct access to the website for the machine, which contains information such as tips and tricks for the GM 200.

⇒ Press Section (**E1**) to show the QR code.

### 8.7.2 Remote

Selecting Section (**E2**) enables the machine to be controlled using a mobile phone, tablet or PC.

⇒ Press Section (**E2**) to establish a remote connection.

Once the remote connection has been established, control is exclusively using the mobile phone, tablet or PC. Only the stop button for interrupting the process can be selected on the machine itself. All other functions on the touchscreen are inactive.

- ① Further information on connecting the machine to the Wi-Fi module and on the remote controlling of the machine can be found in the separate Retschbox manual.

### 8.7.3 Brightness

- In section (E3), the brightness of the display can be set between 6 % and 100 %.
- ⇒ Press on section (E3). The background is highlighted in grey and the border of the rotary knob lights up blue.
  - ⇒ Turn the rotary knob (B4) until the desired brightness of the display is reached.

The set value is applied as soon as section (E3) or another section is pressed again, or as soon as the settings are exited.

### 8.7.4 Software Versions

The following two software versions of the machine can be viewed in Section (E4):

- Display (E4.1) (program control)
- Firmware (E4.2) (device control)

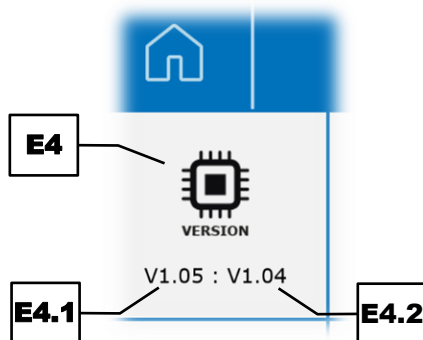

Fig. 10: Software versions

The current software versions are shown in succession.

### 8.7.5 Operating Hours

In section (E5), the operating hours of the device are displayed in hours, minutes and seconds (hh:mm:ss). The process times, i.e. the times between start and stop are counted. The time cannot be manipulated.

### 8.7.6 Software Update

The software can be updated using Section (E7). **NOTICE** A suitable USB data medium must be inserted in the USB interface (K). The main directory may only contain the software to be installed. The machine then automatically detects the new software.

- ⇒ Press the  symbol (E7) to perform an update.
- ⇒ Wait until the transfer and installation have been completed. The knob (B4) flashes until the control element has been restarted. This can take a few seconds.

**NOTICE** Error message "E80" is shown if no USB data medium has been connected or if an external PC has been connected to the USB interface (K).

---

**NOTICE** The USB storage device must be formatted in the FAT32 file system. USB 3.0 storage devices are not supported.

### 8.7.7 Service Environment

Section **(E8)** provides access to the service environment. The service environment is only accessible to service technicians from Retsch GmbH.

**NOTICE** If the service environment has been activated by pressing Section **(E8)**, the USB interface **(K)** is activated and “On” displayed beneath the  symbol, however no other function is executed.



⇒ Deactivate the service environment by pressing Section **(E8)**, or exit the “Settings” menu using the  button **(B1.5)**.

**NOTICE** All other functions remain deactivated while the service environment is activated.

## 9 Error Messages and Information Notes

### 9.1 Error Messages

Error messages inform the user about detected device or programme errors. In the event of an error message, a fault has occurred, in which the operation of the device or the programme is automatically interrupted. Such faults must be resolved before next startup.

Error code	Description	Measures
E10	Drive overload	<ul style="list-style-type: none"> <li>⇒ Switch off the main switch and wait for 30 s before switching on again.</li> <li>⇒ Restart the grinding process, with a smaller amount of sample material.</li> <li>⇒ If the error persists, contact service.</li> </ul>
E11	Failure drive / motor	<ul style="list-style-type: none"> <li>⇒ Switch off the main switch and wait for 30 s before switching on again.</li> <li>⇒ If the error persists, contact service.</li> </ul>
E12	Failure motor break	<ul style="list-style-type: none"> <li>⇒ Switch off the main switch and wait for 30 s before switching on again.</li> <li>⇒ If the error persists, contact service.</li> </ul>
E20	Failure main board	<ul style="list-style-type: none"> <li>⇒ Switch off the main switch and wait for 30 s before switching on again.</li> <li>⇒ If the error persists, contact service.</li> </ul>
E25	Failure display	<ul style="list-style-type: none"> <li>⇒ Switch off the main switch and wait for 30 s before switching on again.</li> <li>⇒ If the error persists, contact service.</li> </ul>
E41	Failure speed sensor	<ul style="list-style-type: none"> <li>⇒ Exit the error message via the  button.</li> <li>⇒ If the error persists, contact service.</li> </ul>
E42	Failure temperature sensor 1 (motor)	<ul style="list-style-type: none"> <li>⇒ Switch off the main switch and wait for 30 s before switching on again.</li> <li>⇒ Allow the motor cool down before restart.</li> <li>⇒ If the error persists, contact service.</li> </ul>
E50	Failure in safety circuit	<ul style="list-style-type: none"> <li>⇒ Switch off the main switch and wait for 30 s before switching on again.</li> <li>⇒ If the error persists, contact service.</li> </ul>
E51	Safety switch defective (locking)	<ul style="list-style-type: none"> <li>⇒ Exit the error message via the  button.</li> <li>⇒ If the error persists, contact service.</li> </ul>
E52	Failure cover switch	<ul style="list-style-type: none"> <li>⇒ Switch off the main switch and wait for 30 s before switching on again.</li> <li>⇒ If the error persists, contact service.</li> </ul>
E80	Failure interface	<ul style="list-style-type: none"> <li>⇒ Exit the error message via the  button.</li> <li>⇒ If the error persists, contact service.</li> </ul>

## 9.2 Information Notes

Notices inform the user on specific device or programme processes. The operation of the device or programme may be interrupted briefly, but there is no fault. The information notice must be acknowledged by the user to continue the process. Information notices provide additional information for the user as an aid, but do not represent any device or programme errors.

Notice code	Description	Measures
H10	Allow drive to cool down!	<ul style="list-style-type: none"><li>⇒ Confirm the message on the control panel.</li><li>⇒ Stop the grinding process.</li><li>⇒ Allow the device to cool down.</li></ul>

## 10 Return for Service and Maintenance



**Fig. 11:** Return form

The acceptance of devices and accessories of the Retsch GmbH for repair, maintenance or calibration can only be effected, if the return form including the decontamination declaration service has been correctly and fully completed.

- ⇒ Download the return form located in the download section "Miscellaneous" on the Retsch GmbH homepage (<http://www.retsch.com/downloads/miscellaneous/>).
- ⇒ When returning a device, attach the return form to the outside of the packaging.

In order to eliminate any health risk to the service technicians, Retsch GmbH reserves the right to refuse the acceptance and to return the respective delivery at the expense of the sender.

## 11 Cleaning, Wear and Maintenance

### CAUTION

C18.0013

#### Risk of injury

Improper repairs

- Unauthorised and improper repairs can cause injuries.
- **Repairs to the device may only be carried out by the Retsch GmbH , an authorised representative or by qualified service technicians.**
- **Do not carry out any unauthorised or improper repairs to the device!**

### 11.1 Cleaning

### WARNING

W6.0003

#### Risk to life caused by an electric shock

Cleaning live parts with water

- Cleaning the device with water can lead to life-threatening injuries caused by an electric shock if the device has not been disconnected from the power supply.
- **Only carry out cleaning work on the device when it has been disconnected from the power supply.**
- **Use a cloth moistened with water for cleaning.**
- **Do not clean the device under running water!**



### CAUTION

C19.0031

#### Risk of injury

Cleaning with compressed air

- When using compressed air for cleaning purposes dust and remnant of the sample material can be flung around and injure eyes.
- **Always wear safety glasses when cleaning with compressed air.**
- **Observe the material safety data sheets of the sample material.**



### NOTICE

N16.0009

#### Damage to the housing and device

Use of organic solvents

- Organic solvents may damage plastic parts and the coating.
- **The use of organic solvents is not permitted.**

⇒ Clean the housing of the device with a damp cloth and if necessary, with a household cleaning agent. Pay attention that no water or cleaning agent enters the interior of the device.

⇒ Clean the control elements of the device with a damp cloth only when it is switched off!

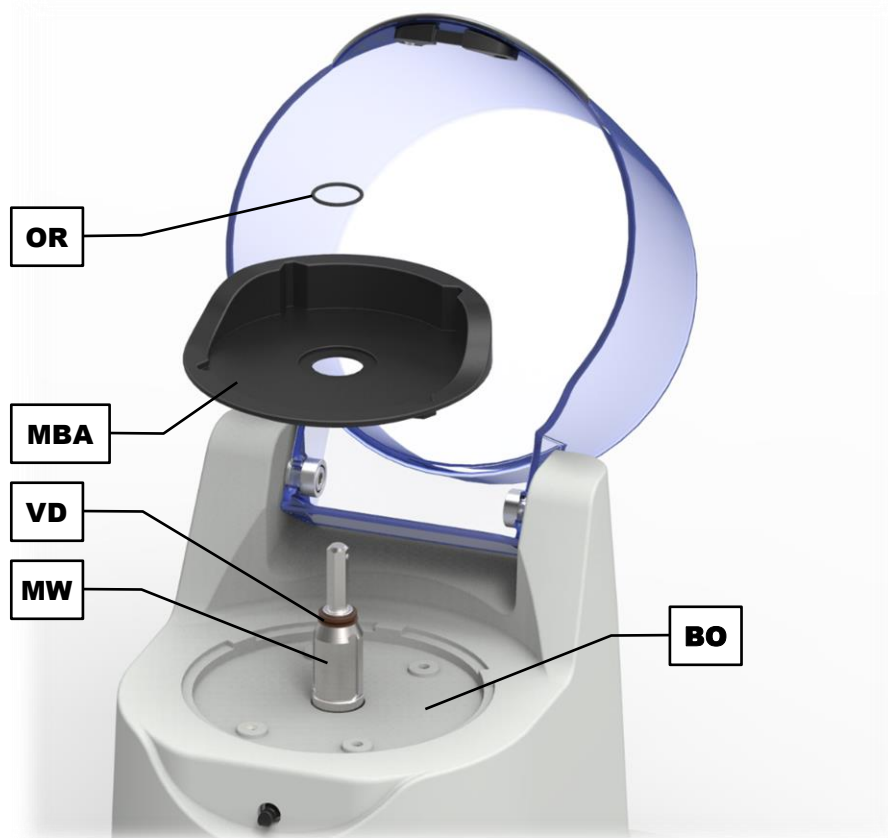

**Fig. 16:** Cleaning the grinding container receptacle

In case of frequent and heavy contamination of the grinding container receptacle (**MBA**) with liquid or greasy samples, sample material can get under the grinding container receptacle.

- ⇒ Remove the O-ring (**OR**), which seals the grinding container receptacle.
- ⇒ Remove the grinding container receptacle (**MBA**) and clean its underside.
- ⇒ Clean the area (**BO**) underneath the grinding container receptacle.
- ⇒ When re-installing the grinding container receptacle, ensure that the O-ring (**OR**) is correctly seated in the groove on the motor shaft (**MW**).

**NOTICE** Check the degree of contamination at regular intervals. Sample material can otherwise enter the interior of the device under unfavourable circumstances.

### 11.1.1 Cleaning the Grinding Set

The cleaning of the grinding set consisting of grinding container, lid and knife insert should be carried out regularly. All parts can be cleaned with alcohol, petrol or normal household detergent. In addition, all parts are dishwasher suitable.

Except for the plastic grinding container made of PP (polypropylene), all parts are also autoclavable.

### 11.2 Wear

The grinding sets may become worn, depending on the frequency of the grinding operation and the sample material. The grinding sets should be regularly checked for wear and replaced if necessary. **NOTICE** Never use plastic containers, which have stress cracking! Those must be replaced immediately!



Likewise, all existing sealing gaskets (of grinding sets and in the device) should be checked for wear regularly and replaced if necessary.

**V-ring sealing gasket on the motor shaft:**

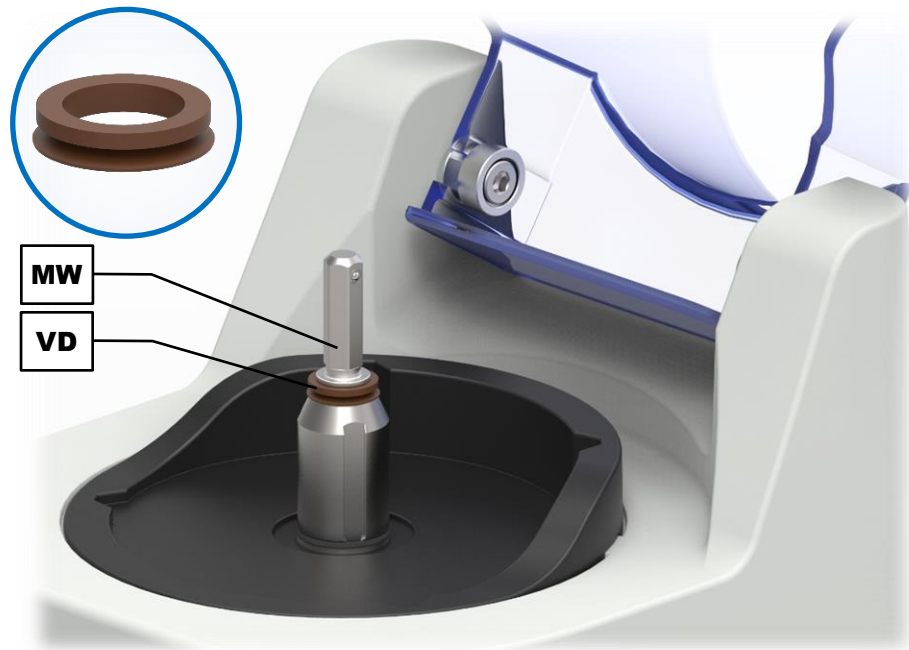

**Fig. 17:** Checking the V-ring sealing gasket

- ⇒ Check the V-ring sealing gasket (**VD**) at regular intervals for damage.
- ⇒ Exchange the V-ring sealing gasket if damaged.

**NOTICE** If the V-ring sealing gasket (**VD**) is damaged, moisture can enter the interior of the device.

## 12 Maintenance

The GM 200 is largely maintenance-free.

In order to ensure the operational safety of the device, the locking mechanism (**A**) and the retaining bracket of the locking mechanism (**FV**) on the hood (**F**) should be checked and cleaned if necessary at each cleaning.

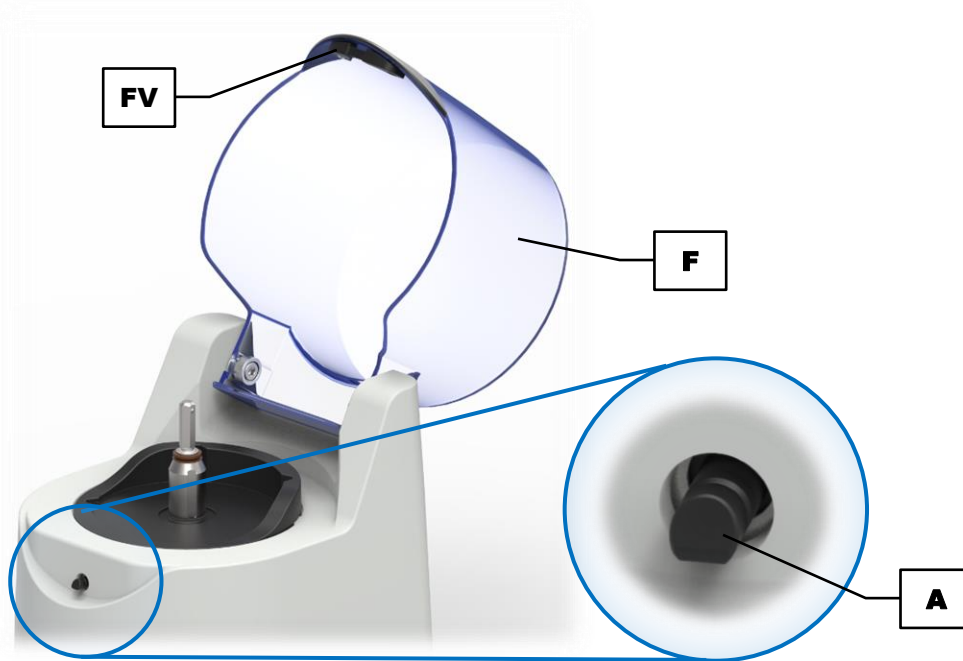

**Fig. 18:** Checking the locking mechanism

---

## 13 Accessories

Information on available accessories as well as the respective manuals are accessible directly on the Retsch GmbH homepage (<https://www.retsch.com>) under the heading "Downloads" of the device.

Information on wear parts and small accessories can be found in the Retsch GmbH general catalogue also available on the homepage.

In case of any questions concerning spare parts please contact the Retsch GmbH representative in your country, or Retsch GmbH directly.

## 14 Disposal

In the case of a disposal, the respective statutory requirements must be observed. In the following, information on the disposal of electrical and electronic devices in the European Community are given.

Within the European Community the disposal of electrically operated devices is regulated by national provisions that are based on the EU Directive 2012/19/EU on Waste Electrical and Electronic Equipment (WEEE).

Accordingly, all devices supplied after August 13<sup>th</sup> 2005 in the business-to-business area, to which this product is classified, may no longer be disposed of with municipal or household waste. To document this, the devices are provided with the disposal label.

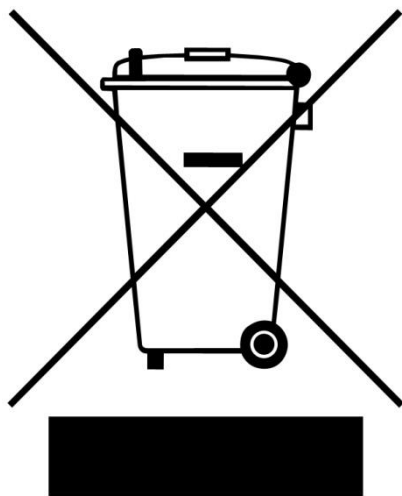

**Fig. 19:** Disposal label

Since the disposal regulations worldwide and also within the EU may differ from country to country, the supplier of the device should be consulted directly in case of need.

This labelling obligation is applied in Germany since March 23<sup>rd</sup> 2006. From this date on, the manufacturer must provide an adequate possibility of returning all devices delivered since August 13<sup>th</sup> 2005. For all devices delivered before August 13<sup>th</sup> 2005 the end user is responsible for the proper disposal.

---

## 15 Index

- A**
- Accessories .....59
  - Achieving good homogenisation results .....34
  - Activatable parameters .....41
  - Adjustable parameters .....39
  - Air vents .....25
  - Ambient temperature .....18
  - Amendment status .....6
  - Amperage .....20
- B**
- Back .....25
  - Bar code .....20
  - Blade protection .....33
  - Blade protector .....33
  - Boost .....42
  - Brightness .....50
- C**
- Calibration .....54
  - Capacity .....20
  - CE marking .....19
  - Cleaning .....55
  - Closing .....26
  - CO<sub>2</sub> .....34
  - Complaints .....17
  - Condensation .....18
  - Confirmation form for the managing operator .....11
  - Control element .....25, 38
  - Control panel
    - areas .....37
  - Controlling the device .....37
  - Copyright .....6
  - Correct filling when grinding using dry ice .....32
  - Correct filling when grinding using dry ice .....32
  - Corrugated grinding jars for improved mixing of the sample .....35
  - Cryogenic grinding .....31, 32
- D**
- Deactivatable parameters .....41
  - Degree of protection .....14
  - Depth .....15
    - with open hood .....15
  - Device
    - close .....26
    - open .....26
  - Device control .....37
  - Device designation .....19
  - Dimensions .....15
  - Direction of rotation .....38, 41
  - Disclaimer .....6
  - Disconnection from the mains .....21
  - Display .....37
    - Software .....50
  - Displays .....37
- Disposal ..... 60
  - label ..... 19, 60
  - regulations ..... 60
- Dry ice ..... 32, 34
- Dry ice ..... 32
- E**
- Electrical connection ..... 19
  - Electromagnetic compatibility ..... 15
  - Embrittlement ..... 34
  - Embrittling the sample material ..... 32
  - EMC ..... 15
  - Emissions ..... 14
  - Equivalent continuous sound level ..... 14, 15
- Error
- E10 ..... 52
  - E11 ..... 52
  - E12 ..... 52
  - E20 ..... 52
  - E25 ..... 52
  - E41 ..... 52
  - E42 ..... 52
  - E50 ..... 52
  - E51 ..... 52
  - E52 ..... 52
  - E80 ..... 50, 52
- Error messages ..... 52
- Excess pressure ..... 35
- Explanations of the safety instructions ..... 8
- External fuse ..... 19
- F**
- Feed grain size ..... 16
  - Feed volume ..... 16
  - Field of application of the machine ..... 11
  - Filling
    - outside the device ..... 29
    - within the device ..... 29
  - Firmware ..... 50
  - First commissioning ..... 21
  - Frequency ..... 19
  - Front ..... 24
  - Front view ..... 24
  - Full-metal knife ..... 32
    - cleaning ..... 34
  - Functions ..... 37, 38
  - Fuse
    - external ..... 19
  - Fuse strength ..... 20
  - Fuse type ..... 20
- G**
- General catalogue ..... 59
  - General safety instructions ..... 9
  - Gravity lid ..... 31
    - with overflow channels ..... 31

Grinding by means of cold grinding .....	34	Maintenance .....	11, 54, 55, 57
Grinding container .....	24	Manual .....	6, 9, 11
closing .....	30	Manual mode .....	39, 41, 42
filling .....	29	Manufacturer's address .....	19
glass container .....	27	Maximum relative humidity .....	18
inserting .....	27	Minimising wear to the blade .....	34
lid .....	24	Motor .....	
plastic container .....	27	electric emergency brake .....	14
stainless steel container .....	27	Motor rotation speed .....	15
Grinding jar .....	25	myRetsch .....	49
lid .....	25	<b>N</b>	
Grinding noise .....	14	Navigation .....	37, 39
Grinding parameters .....	39	Notes on the manual .....	6
Grinding set .....		Number of fuses .....	20
cleaning .....	56	<b>O</b>	
<b>H</b>		On/off switch .....	26
Handling the full-metal cutter .....	33	Open .....	38
Hearing loss .....	14	Opening .....	26
Height .....	15	Operating controls .....	24, 37
with open hood .....	15	Operating hours .....	50
Hood .....	24, 25	Operating instructions .....	11
Housing fan .....	25	Operating mode .....	
Humidity .....	18	change .....	39
<b>I</b>		manual .....	39
Improper use .....	11	programme .....	39
Information note .....		sequence .....	39
H10 .....	53	Operating modes .....	39
Information notes .....	52, 53	Operating the device .....	22
Installation .....	17	Organic solvents .....	22
Installation height .....	18	Organic solvents .....	55
Installation site .....		<b>P</b>	
conditions .....	18	Packaging .....	17
Intended use of the device .....	11	Part number .....	19
Interface .....		Permanent grinding .....	42
Wi-Fi connection .....	26	Power version .....	20
Interval .....	38, 41	Pre-crushing in reverse mode .....	34
<b>K</b>		Principle of operation .....	23
Knife insert .....	24	Process .....	
Knife insert .....		start .....	42
inserting .....	28	stop .....	43
Knob .....	25	Process time .....	38, 41
<b>L</b>		Program .....	
$L_{eq}$ .....	14, 15	editing .....	45
lid .....	24	selecting .....	43
Lid .....	25	Programme .....	
<b>Lid becoming pressed on when grinding using</b>		deleting .....	45
<b>dry ice</b> .....	34	saving .....	45
Liquid nitrogen .....	31, 32	Programme memory position .....	43
Location requirements .....	15	Programme mode .....	39, 41, 43
Locking mechanism .....	14, 24, 58	functions .....	43
Long-term operation .....	23	Programme number .....	44
<b>M</b>		Programme overview .....	44
Mains connection .....	26	Programme settings .....	38
Mains frequency .....	20	Protective equipment .....	14
Mains supply .....	19	Prozess time .....	39

<b>Q</b>			
Quick Start .....	38, 42		
<b>R</b>			
Range of application of the device .....	23		
Rated power .....	15		
Rear view .....	25		
Receptacle volume .....	16		
Reduction lid .....	31		
Remote .....	49		
Repair .....	10, 54, 55		
Repair instructions .....	10		
Required floor space.....	15		
Return .....	17		
for service and maintenance .....	54		
Return device.....	60		
Return form.....	54		
<b>Risk of injury due to dry ice</b> .....	33, 35		
Risk of injury to eyes and skin due to severe frostbite.....	35		
Rotary knob .....	24, 39, 40, 50		
RPIO .....	26		
<b>S</b>			
Safety.....	7		
Safety Officer .....	7		
Sequence			
deleting.....	47		
editing.....	47		
saving .....	47		
selecting .....	46		
Sequence mode.....	45		
functions.....	46		
Sequence number .....	46		
Sequence settings .....	38		
Serial number .....	19		
Service address .....	10		
Service environment.....	51		
Settings .....	37, 38, 47, 48, 49		
Signs .....	6		
Small accessories .....	59		
Software			
update .....	50		
versions.....	50		
Software versions .....	50		
Sound level .....	14		
Sound parameters .....	14		
Spare parts .....	59		
Special lid for cryogenic grinding .....	35		
Speed.....	38, 39, 41		
Standard lid.....	30, 31		
Start.....	38		
Stop.....	38		
Switching on / off.....	26		
Symbols .....	6		
<b>T</b>			
Target group .....	7		
Technical data.....	14		
Temperature fluctuations .....	18		
Temperature range .....	18		
Temporary storage.....	18		
Touchscreen .....	39		
Transport.....	17		
Transport damage.....	17		
Type plate .....	19, 26		
description .....	19		
<b>U</b>			
USB interface .....	26		
<b>V</b>			
Ventilation properties .....	34		
Vibrations .....	21		
Views of the device .....	24		
Voltage .....	19		
<b>W</b>			
Warning.....	8		
Information .....	9		
Warranty claim .....	17		
Warranty claims .....	9		
Wear.....	55, 56		
Wear parts .....	59		
Weight .....	15		
Width.....	15		
Workplace related emission level .....	14, 15		
<b>Y</b>			
Year of production.....	19		

## KNIFE MILL

GRINDOMIX GM 200 | 20.254.xxxx

### EU DECLARATION OF CONFORMITY

Herewith we declare, represented by the signatory, that the above mentioned device complies with the following directives and harmonized standards:

#### Machinery Directive 2006/42/EC

Applied standards, in particular:

DIN EN ISO 12100 Safety of machinery  
DIN EN ISO 13849-1 Safety of machinery - Safety-related parts of control systems

In compliance with:

DIN EN 13683 Garden equipment - Integrally powered shredders/chippers - Safety

#### EMC Directive 2014/30/EU

Applied standards, in particular:

DIN EN 55011 Industrial, scientific and medical equipment - Radio-frequency disturbance characteristics - Limits and methods of measurement  
DIN EN 61000-3-2 Electromagnetic compatibility (EMC)  
DIN EN 61000-3-3 Electromagnetic compatibility (EMC)  
DIN EN 61326-1 Electrical equipment for measurement, control and laboratory use - EMC requirements

#### Low Voltage Directive 2014/35/EU

Applied standards, in particular:

DIN EN 61010-1 Safety requirements for electrical equipment for measurement, control and laboratory use

#### Authorized person for the compilation of technical documents:

Dr. Loredana Di Labio (technical documentation)

Furthermore, we declare that the relevant technical documentation for the above mentioned device has been compiled according to Annex VII Part A of the Machinery Directive, and we undertake to submit this documentation on request to the market surveillance authorities.

**In case of a modification of the device not previously agreed with Retsch GmbH, as well as the use of unauthorised spare parts or accessories, this declaration will lose its validity.**

Retsch GmbH



Dr. Ing. Frank Janetta, Team Leader R&D Department

part of  VERDER  
scientific

© Retsch GmbH · Retsch-Allee 1-5 · 42781 Haan · Germany  
www.retsch.com · e-mail: info@retsch.com · phone: +49 2104 2333-100

Haan, 09/2017







**Retsch**<sup>®</sup>

**Copyright**

© Copyright by  
Retsch GmbH  
Retsch-Allee 1-5  
42781 Haan  
Germany